



LAMAR UNIVERSITY

MEMBER THE TEXAS STATE UNIVERSITY SYSTEM™

Chemical Hygiene Plan

Publication Date: April 2024

EHS & Risk Management
Lamar University
PO Box 10807
Beaumont, TX 77710

Phone: (409) 880.7249

Email: riskmanagment_ehs@lamar.edu



LIST OF ACRONYMS

ACGIH	American Congress of Governmental Industrial Hygienists
ANSI	American National Standards Institute
BSC	Biological Safety Cabinet
BSL	Biological Safety Level
CDC	Centers for Disease Control and Prevention
CFR	Code of Federal Regulations
CHO	Chemical Hygiene Officer
CHP	Chemical Hygiene Plan
DEP	Department of Environmental Protection
DNA	Deoxyribonucleic Acid
rDNA	Recombinant Deoxyribonucleic Acid
DOT	Department of Transportation
HEPA	High Efficiency Particulate Air
IACUC	Institutional Animal Care and Use Committee
LFPM	Linear Feet per Minute
LSO	Laser Safety Officer
LU	Lamar University
MSDS	Material Safety Data Sheet
NFPA	National Fire Protection Association
NIH	National Institutes of Health
OSHA	Occupational Safety and Health Administration
PEL	Permissible Exposure Limit
PI	Principal Investigator
PPE	Personal Protective Equipment
RCRA	Resource Conservation and Recovery Act
RSO	Radiation Safety Officer
SDS	Safety Data Sheet
SOP	Standard Operating Procedure



Table of Contents

EFFECTIVE DATE..... ii
RECORD OF CHANGE..... ii
LIST OF ACRONYMS..... iii
Table of Contents..... iv
1 – INTRODUCTION..... 1
2 – IMPLEMENTATION 1
3 – ROLES AND RESPONSIBILITIES 2
4 – DEFINITIONS..... 5
5 – ADMINISTRATIVE DETAILS 6
6 – COMPONENTS OF A CHEMICAL HYGIENE PLAN 6
7 – BASIC SAFETY PRACTICES 7
7.1. Safety Incidents and Spills 7
7.2. Avoidance of “Routine” Exposure 8
7.3. Choice of Chemicals/Waste Minimization..... 8
7.4. Shipping and Receiving Hazardous Materials..... 9
7.5. Compressed Gas Cylinders 9
7.6. General Laboratory Safety Guidelines..... 10
Eating, Smoking, etc. 10
General Housekeeping and Apparel 10
Handling Equipment and Glassware 11
Unattended Operations 11
Working Alone..... 11
Children Prohibited 11
Planning Operations..... 12
Waste Disposal 12
Laboratory Contact Information 12
Laboratory Security 12
8 – EXPOSURE CONTROL MEASURES..... 12
8.1. Exposure Determination..... 13
8.2. Engineering Controls 13
General Ventilation 13
Local Exhaust..... 13



8.3. Personal Protective Equipment.....	14
Eye/Face Protection	14
Gloves.....	15
Respirators	15
8.4. Lab Coats & Aprons	15
General.....	15
Disposable Lab Coats and Aprons	16
Reusable Lab Coats and Aprons Contaminated with Chemicals.....	16
Reusable Lab Coats and Aprons Contaminated with Pathogens	16
Reusable Lab Coats and Aprons Contaminated with Radionuclides.....	17
Onsite Lab Coat and Apron Laundering	17
8.5. Proper Storage and Handling of Chemicals	17
Flammable Chemical Storage.....	18
Corrosive Liquid Storage	19
Oxidizing Agents.....	19
Table II Examples of Oxidizing Agents ¹	20
Peroxidizable Compounds.....	20
Highly Reactive (Shock Sensitive) Chemicals	20
Toxic Chemical Storage	20
Crossover Properties.....	21
Storage of Chemical in Refrigerators	21
Labeling	21
Moving Chemicals on Campus	21
Secondary Containment.....	22
Overpacking	22
Hazard Classification	22
Amount Being Moved	23
Concentration.....	23
Conclusion.....	24
8.6. Shipping of Hazardous Chemicals.....	24
8.7. Safety Equipment	24
9 – FUME HOODS.....	25
9.1. General Purpose Hoods.....	25



9.2. Special Purpose Hoods	25
Perchloric Acid Fume Hoods	25
Radioisotope Fume Hoods	26
General Safety Practices for Fume Hoods.....	26
10 – BIOSAFETY CABINETS AND LAMINAR FLOW HOODS.....	27
10.1.Biosafety Cabinets	27
Class I Biosafety Cabinet	27
Class II Biosafety Cabinet	27
Class III Biosafety Cabinet	28
10.2.Laminar Flow Hoods	28
10.3.Materials, Designs and Construction.....	28
10.4.Performance, Inspection and Certification.....	28
11 – LOCAL EXHAUST ENCLOSURES AND SNORKELS.....	29
12 – EMPLOYEE INFORMATION AND TRAINING.....	29
12.1.Employee Information.....	29
12.2.Employee Training	30
Initial Safety Training.....	30
Annual Refresher Training.....	30
Laboratory-Specific Training	30
12.3.Information and Training Responsibilities.....	31
13 – ACTIVITIES REQUIRING PRIOR APPROVAL	31
Table III Activities and Approving Bodies	31
14 – MEDICAL CONSULTATIONS/EXAMINATIONS.....	32
15 – PARTICULARLY HAZARDOUS SUBSTANCES.....	33
15.1.Guidelines for Handling Some Specific Hazardous Chemicals.....	34
Allergens and Embryotoxins.....	34
Chemicals of Moderate Chronic or High Acute Toxicity	34
Chemicals of High Chronic Toxicity	35
Working with Perchloric Acid.....	37
Conducting Procedures with Hydrofluoric Acid.....	37
Nanomaterials.....	38
Appendix A: Research/ Laboratory SOP	39
Appendix B – Biological Material Hazard Assessment.....	49
Appendix C: Hazardous Materials Shipping/Receiving Guide.....	52



C-2	What are Hazardous Materials and Dangerous Goods?	52
C-3	Lamar University Procedures for Offering Hazardous Materials for Shipment	52
C-4	Receiving Hazardous Materials	53
C-5	Training Requirements	54
C-6	Additional Information: US Postal Service Suspicious Package Guidelines	54
C-7	Laboratories Shipping Hazardous Chemicals	54
Appendix D:	Hazardous Material Emergencies and Spills	56
Appendix E:	Forms & Checklists	62
	Emergency Responder Contact Information	62
	General Emergency Procedures	63
Appendix F:	Glossary	70
Appendix G:	Diagrams of Local Exhaust Devices	76
Appendix H:	Overpacking Decision Tree	88
Appendix I:	Minors in Research Laboratories or Animal Facilities	92
Appendix J:	Storing Chemicals Safely	105
	Suggested Storage Limits For Common Peroxidizable Compounds	107
Appendix K:	Glove Selection Chart	111
Appendix L:	Lab Inspection Manual	118
Appendix M:	Hazardous Materials Manual	122
	<i>Flammable Liquid</i>	122
	<i>Combustible Liquid</i>	123
	<i>Flammable Solid</i>	123
	<i>Oxidizer</i>	123
	<i>Corrosive</i>	123
	<i>Organic Peroxide</i>	123
	<i>Poison</i>	123
	<i>Explosive</i>	123
	<i>Compressed Gas</i>	123
	<i>Cryogenics</i>	123
	<i>Radioactive</i>	123
Appendix N:	Lab Access Guidelines	130

1 – INTRODUCTION

As a research and educational institution, Lamar University (LU) is morally and legally obligated to provide a safe working environment for all its employees and students. Since LU employs workers engaged in the laboratory use of hazardous chemicals, the University will comply with the provisions of the Occupational Safety and Health Administration (OSHA) standard: "[29 CFR§1910.1450, Occupational Exposure to Hazardous Chemicals in Laboratories.](#)" This standard is commonly referred to as "The OSHA Lab Standard." It was developed to provide increased protection to laboratory employees beyond that which is provided in the General Industry Standards. The OSHA Lab Standard is also a "performance-oriented standard." This means OSHA establishes the minimum requirements, but the methods for achieving these requirements are left up to the employer. The backbone of the Lab Standard is its requirement for employers to develop and carry out the provisions of a written Chemical Hygiene Plan (CHP), which requires development of standard operating procedures (SOPs) for work with hazardous chemicals in laboratories.

With the great diversity of lab activities on campus, it is impossible for any one person to develop SOPs for every activity in every laboratory. However, the performance-oriented nature of this standard makes it possible to construct a general framework that can be used by individual laboratories to meet the requirements of the OSHA Lab Standard.

This document constitutes the LU CHP. It details laboratory safety policies, procedures, and standards at LU. Implementation of the guidelines in this document depends on the cooperation of department chairpersons, faculty, laboratory staff, students, EHS & Risk Management staff and members of safety committees. Although Principal Investigators bear the ultimate responsibility for safe conditions and procedures in their laboratories, each member of a laboratory group is responsible for complying with standards put forth in this document with the common goal of promoting a healthy and safe working environment for employees and students.

There may be some situations in which proper facilities and equipment are not available for conducting project requirements. When this is the case, faculty members should consult EHS & Risk Management for assistance in evaluating hazards and finding ways to conduct activities properly. This document should not be considered a comprehensive review of all potential hazards. Individuals with more specific questions should contact EHS & Risk Management directly.

In addition to the requirements of the CHP, work in laboratories involving biological or radiological materials must comply with Lamar University's [Biological Safety Manual](#) and [Radiation Safety Manual](#).

2 – IMPLEMENTATION

The Chemical Hygiene Plan will be implemented and administered by the Chemical Hygiene Officer, a member of the Department of EHS & Risk Management. The Chemical Hygiene Officer is responsible for developing, implementing, and reviewing the written Chemical Hygiene Plan, which will be reviewed annually and updated as needed.

Although the Chemical Hygiene Officer is responsible for the development and implementation of the Chemical Hygiene Plan, it is important to realize that the responsibility for chemical hygiene rests at all levels of the University.

3 – ROLES AND RESPONSIBILITIES

Individuals overseeing or working in laboratories where hazardous chemicals are used or stored are responsible for following the guidelines listed in the *Chemical Hygiene Plan*. This plan does not apply to undergraduates or other students enrolled in laboratory courses in teaching labs where hazardous chemicals may be used or stored, though they are still responsible for behaving safely within the laboratory, according to classroom rules. The responsibilities of each position under the Chemical Hygiene Plan (CHP) are outlined as follows:

1. **The President of the University**, as the chief executive, has ultimate responsibility within the institution, and along with other administrators, provides continuing support for the CHP.
2. **Associate Provost for Research and Sponsored Projects** provides institutional leadership and assumes delegated responsibility to ensure compliance with the CHP. The Associate Provost for Research and Sponsored Projects supplies the University Chemical Hygiene Officer with the support necessary to implement and maintain the requirements of the CHP. The Associate Provost for Research and Sponsored Projects updates the University President on policies, programs, and relevant issues regarding laboratory safety.
3. **The University Chemical Hygiene Officer (EHS Chemical Safety Manager)** is responsible for developing, implementing, and updating the CHP on behalf of the University President, or designated representative. The Chemical Hygiene Officer will assist departments and individual laboratories in implementing and complying with the CHP. The Chemical Hygiene Officer must also institute appropriate audit methods to ensure compliance, and inspects laboratories as outlined in the *Laboratory Inspection Program*. The Chemical Hygiene Officer conducts *Laboratory & Chemical Waste Management* training and investigates chemical safety incidents involving hazardous chemicals.
4. **Department Chairs** are responsible for compliance with the CHP within their areas. This includes:
 - Ensuring that all employees, guests, and visiting scientists working within their areas are informed of, and adhere to, chemical hygiene practices as outlined in the LU CHP.
 - Instructing lab personnel within their department to receive *Initial Lab Safety & Chemical Waste Management* training and annual retraining through EHS.
 - Working with principal investigators or laboratory/facility managers, within their departments, found to be in violation of the CHP or the *Fire/Life Safety Code* to ensure timely corrective action.
 - Reviewing accident reports and works with principal investigators, laboratory/facility managers, lab personnel, and EHS to make appropriate changes to laboratory standard operating procedures to prevent future incidents from occurring.
5. **Principal Investigators (PI)** have overall responsibility for chemical hygiene in their laboratories and must ensure compliance with the CHP, the Laboratory Chemical Inventory Program, the Laboratory Inspection Program, and the Chemical Waste Disposal Program. Each PI will:
 - Ensure that their lab personnel, including the PI, complete *Initial Lab Safety & Chemical Waste Management* training provided by EHS prior to working in or overseeing work done in the lab. A refresher course must be completed annually by the PI and their lab personnel.
 - Develop and implement standard operating procedures (see [Appendix A: Standard Operating Procedures](#)) and training programs specific to the work being carried out in their laboratories including lab-specific documentation for lab personnel trained.



- Maintain current inventories for all chemicals stored in their laboratories and/or in other storage areas and have (Material) Safety Data Sheets - (M)SDSs readily accessible for all hazardous chemicals stored in their laboratories.
 - Ensure compliance with the University's Working Alone Policy.
 - Ensure that minors (individuals under 18 years old) will be supervised at all times by qualified laboratory personnel.
 - Provide appropriate personal protective equipment to personnel in their labs
 - Review and approve protocols and procedures of lab personnel for potential safety and/or technical issues prior to active research.
 - Ensure lab personnel properly collect, label, and manage wastes.
 - Minimize or eliminate actual or potential hazards that could lead to accidents, injuries, or property damage.
 - Ensure that lab(s) remains clean, orderly, and in a sanitary condition.
 - Ensure safe operation of laboratory equipment through proper installation, inspection, maintenance, and repair.
 - Ensure that any materials transport required for the lab's operations is done by individuals with appropriate training, using appropriate signage, in accordance with applicable regulations.
 - Contact EHS when safety showers, eyewash stations, fume hoods, or other safety-related equipment are not working properly.
 - Report all lab-related safety incidents/emergencies to LUPD (911) and injuries to Human Resources. Serious injuries (i.e., death, in-patient hospitalization, amputation, or loss of an eye) must be reported to EHS immediately to allow for compliance with OSHA reporting time requirements. Significant chemical spills should also be reported to EHS immediately to allow for compliance with local, state, and federal chemical spill reporting regulations. Near miss safety incidents (i.e., incidents that did not result in injury, illness, or damage, but had the potential to do so given a slight shift in circumstances) should also be documented and reported to EHS for review.
 - Acknowledge that he/she may designate an individual working in their lab(s) to collaborate with him/her to enact lab-specific safety policies and procedures; however, designation of such an individual does not absolve the PI of the responsibilities listed in this section. The PI is ultimately responsible for ensuring health and safety in the lab(s).
6. **Laboratory/Facility Managers** oversee a shared laboratory/equipment space. Laboratory/Facility Managers follows the guidelines of the CHP and ensure compliance with all EHS policies and programs applicable to the labs or facilities they oversee. Laboratory/Facility Managers will:
- Ensure all individuals assigned to the lab/facility, including the Lab/Facility Manager, complete *Initial Lab Safety & Chemical Waste Management* training provided by EHS prior to working in or overseeing work done in the lab. A refresher course must be completed annually by the Lab/Facility Manager and all lab personnel.
 - Maintain an accurate chemical inventory for each laboratory.
 - Informs laboratory users of the actual and potential hazards of chemicals, equipment, and operations of the shared laboratory/equipment space.
 - Provide appropriate personal protective equipment to personnel in their lab/facility.
 - Ensure wastes are properly collected, labeled, stored, and managed.
 - Minimize or eliminate actual or potential hazards that could lead to accidents, injuries, or property



- damage.
- Report all lab-related safety incidents/emergencies to LUPD (911) and injuries to Human Resources. Serious injuries (i.e., death, in-patient hospitalization, amputation, or loss of an eye) must be reported to EHS immediately to allow for compliance with OSHA reporting time requirements. Significant chemical spills should also be reported to EHS immediately to allow for compliance with local, state, and federal chemical spill reporting regulations. Near miss incidents (i.e., incidents that did not result in injury, illness, or damage, but had the potential to do so given a slight shift in circumstances) should also be documented and reported to EHS for review.
 - Ensure that lab(s)/facility remains clean, orderly, and in a sanitary condition.
 - Ensure authorized lab personnel are properly trained for use of laboratory equipment.
 - Ensure that any materials transport required for the lab's operations is done by individuals with appropriate training, using appropriate signage, in accordance with applicable regulations.
 - Contact EHS when safety showers, eyewash stations, fume hoods, or other safety-related equipment are not working properly.
7. **Laboratory Workers** are ultimately responsible for developing and applying good chemical hygiene practices as outlined in the CHP. Lab Workers will:
- Review and follow policies, procedures, and work practices outlines in the CHP and lab-specific procedures.
 - Attend *Initial Lab Safety & Chemical Waste Management* training prior to working in a lab.
 - Stay current with Lab Safety & Chemical Waste Management training by attending initial or refresher training annually.
 - Use engineering, administrative, and work practice controls to minimize exposure to hazards present in the lab.
 - Always wear the appropriate personal protective equipment as specified in Safety Data Sheets (SDS), Standard Operating Procedures (SOPs) or other applicable documentation.
 - Receive approval from the principal investigator or laboratory/facility manager prior to conducting research involving hazardous chemicals, and prior to making changes to existing, reviewed procedures.
 - Properly collect, handle, label, store, and manage hazardous chemicals and wastes.
 - Ensure that lab remains clean, orderly, and in a sanitary condition.
 - Report all safety incidents, injuries, near misses, spills, and illnesses to the principal investigator or lab/facility manager. (see also [Appendix D](#)).
 - Adheres to all University, Departmental, and laboratory-specific safety policies, procedures, and directives.
8. **Minors**, individuals under 18 years old, are not allowed in laboratories that contain health or physical hazards unless they are Lamar University students or registered participants in a University-sanctioned project or program.
- Minors must be supervised by lab personnel at all times while working in laboratories.
 - Activities involving minors, who are not enrolled or accepted for enrollment in credit-granting courses at the University or who are not employees of the University, must be sponsored by a unit within the University, be registered with the University's Minor Protection Coordinator, and meet University standards described in the *Policy for the Protection of Minors and Reporting of Child Abuse and Neglect* (see also Minors in Laboratories).

4 – DEFINITIONS

The definitions listed below are taken directly from the OSHA Lab Standard ([29CFR§1910.1450\(b\)](#)).

Chemical Hygiene Plan: A written program developed and implemented by an employer which sets forth procedures, materials, personal protective equipment and work practices that (i) are capable of protecting employees from the health hazards presented by hazardous chemicals used in that particular workplace and (ii) meet the requirements of paragraph (e) of the Lab Standard.

Emergency: Any occurrence such as, but not limited to, equipment failure, rupture of containers or failure of control equipment that results in an uncontrolled release of hazardous chemicals in the workplace.

Employee: An individual employed in a laboratory workplace who may be exposed to hazardous chemicals in the course of his or her assignments.

Hazardous chemical: A chemical for which there is statistically significant evidence based on at least one study conducted in accordance with established scientific principles that acute or chronic health effects may occur in exposed employees.

Health hazard: A term that includes chemicals which are carcinogens, toxic or highly toxic agents, reproductive toxins, irritants, corrosives, sensitizers, hepatotoxins, nephrotoxins, neurotoxins, agents which act on the hematopoietic systems, and agents which damage the lungs, skin, eyes, or mucous membranes.

Laboratory: A facility where the "laboratory use of hazardous chemicals" occurs. It is a workplace where relatively small quantities of hazardous chemicals are used on a non-production basis.

Laboratory scale: Work with substances in which the containers used for reactions, transfers, and other handling of substances are designed to be easily and safely manipulated by one person. "Laboratory scale" excludes those workplaces whose function is to produce commercial quantities of materials.

Laboratory-type hood: A device located in a laboratory that is enclosed on five sides with a movable sash or fixed partial enclosure on the remaining side. It is designed to prevent or minimize the escape of air contaminants into the laboratory and to keep the breathing zone of the operator uncontaminated. Walk-in hoods with adjustable sashes meet this definition provided that the sashes are adjusted during use so that the airflow and the exhaust of air contaminants are not compromised, and employees do not work inside the enclosure during the release of airborne hazardous chemicals.

Laboratory use of hazardous chemicals: The handling or use of such chemicals in which all of the following conditions are met:

1. Chemical manipulations are carried out on a "laboratory scale;"
2. Multiple chemical procedures or chemicals are used;
3. The procedures involved are not part of a production process, nor in any way simulate a production process; and
4. "Protective laboratory practices and equipment" are available and in common use to minimize the potential for employee exposure to hazardous chemicals.

Physical hazard: A chemical for which there is scientifically valid evidence that it is a combustible liquid, a compressed gas, explosive, flammable, an organic peroxide, an oxidizer, pyrophoric, unstable (reactive) or water reactive.

Protective laboratory practices and equipment: Those laboratory procedures, practices and equipment accepted by laboratory health and safety experts as effective, or that the employer can show to be effective, in minimizing the potential for employee exposure to hazardous chemicals.

Based on these definitions, the CHP will apply to all areas engaged in the laboratory use of hazardous chemicals. By the definition of 'laboratory use of hazardous chemicals' given here, this includes small-scale use of hazardous materials for purposes outside scientific laboratories, such as use of paint thinners, etching solutions, and paints in art studios.

5 – ADMINISTRATIVE DETAILS

Copies of the Chemical Hygiene Plan will be maintained in either a 3-ring binder or as a link on the laboratory computer(s) desktop, and kept readily accessible in the following locations:*

- Environmental Health and Safety.
- Departmental Head's Office.
- Each laboratory covered by this CHP.

* Alternatively, the CHP can be accessed directly on the [EHS & RISK MANAGEMENT web site](#) . Having the CHP available in these locations will most effectively ensure that employees have access to pertinent safety information. It will also provide a template for new investigators or lab managers to use when new laboratories are brought on-line.

In addition to complying with the CHP, laboratories using radioactive materials and radiation producing devices (X-ray diffractors, electron microscopes, etc.) must follow the policies and procedures outlined in the University's [Radiation Safety Manual](#). Laboratories using Lasers designated Class II or above must also contact the Radiation Safety Officer.

Laboratories where work involving human/primate tissues, recombinant DNA, or pathogenic agents is conducted must comply with Centers for Disease Control and National Institutes of Health guidelines, and follow the policies and procedures outlined in the University's [Biological Safety Manual](#).

6 – COMPONENTS OF A CHEMICAL HYGIENE PLAN

The OSHA Lab Standard specifies that eight elements be addressed in order to ensure the protection of laboratory employees. These eight elements, summarized below, are fully detailed in [29 CFR§ 1910.1450\(e\)\(3\)](#) of the regulation.

1. Basic safety practices for handling hazardous chemicals.
2. Control measures to reduce worker exposures.



3. Fume hood performance.
4. Employee information and training (including emergency procedures).
5. Requirements for prior approval of laboratory activities.
6. Medical consultation and medical examinations.
7. Chemical hygiene responsibilities.
8. Special precautions for work with particularly hazardous substances.

Responsibilities under the Chemical Hygiene Plan (element #7 above) have already been discussed. The remaining elements will be addressed in the pages that follow. This portion of the CHP is generalized and individual lab/facility managers and principal investigators are responsible for tailoring this CHP to the specific needs of their areas. Contact **EHS & RISK MANAGEMENT** with questions about adapting this CHP to a laboratory area. See also [Appendix A: Standard Operating Procedures](#) for more information.

7 – BASIC SAFETY PRACTICES

There are many excellent publications containing guidelines for the safe conduct of laboratory work, such as *Safety in Academic Chemistry Laboratories*, published by the American Chemical Society, and *Prudent Practices in the Laboratory: Handling and Disposal of Chemicals*, published by National Research Council. These publications are concise, readable, and oriented toward academic laboratories. They are recommended reading for all laboratory personnel. Consulting other safety information resources is encouraged- review the references in Appendix F: References or contact the Chemical Hygiene Officer for additional sources.

The following basic safety practices apply to all laboratories¹. Each laboratory must include any specific practices pertaining to Standard Operating Procedures used in that particular lab (see [Appendix A: Standard Operating Procedures](#)).

7.1. Safety Incidents and Spills

- Eye Contact: Immediately flush eyes with water for a minimum of 15 minutes while holding eyelids open. In the event that only one eye has been affected, keep the other eye closed while flushing to minimize the probability of contamination spreading to the unaffected eye during flushing. As soon as flushing begins, contact emergency medical personnel who can provide further evaluation, assistance and treatment to avoid lasting eye injury and/or blindness.
- Ingestion: Consult Safety Data Sheet (SDS) and call the Poison Control Information Center at 1-800- 222-1222 for emergency response information for the specific compound ingested. Seek medical attention immediately. The (M)SDS should accompany the patient to the medical treatment facility.
- Skin Contact: Promptly flush the affected area with water, using safety shower if necessary, (minimum of 15 minutes). Remove any contaminated clothing while flushing with water, using care not to spread chemical contamination to other parts of the body.

¹ Adapted from the National Research Council's, "Prudent Practices in the Laboratory: Handling and Disposal of Chemicals," National Academy Press, Washington, DC, 1995.

If clothing is usually removed by pulling overhead, cut the clothing off instead, using the safety scissors provided in first aid kits. If symptoms persist after washing, seek medical attention.

NOTE: In case of skin contact involving hydrofluoric acid (HF), thoroughly flush the affected area of the body and then curtain flushing. Immediately apply calcium gluconate gel or a 10% ^{w/v} calcium gluconate solution to the affected area and seek medical attention. Application of the calcium gluconate antidote is imperative to minimize the risk of serious, lasting injury or fatality. On arrival, inform emergency medical personnel that a hydrofluoric acid exposure has occurred.

Inhalation: Immediately move the patient to fresh air and seek medical attention. In the event the patient is overcome, evaluate the area for your own personal safety prior to attempting to retrieve the victim. Do NOT attempt a rescue in an unsafe atmosphere without proper PPE and emergency response training. Well-intentioned rescuers have often become a victim as well in these situations, complicating rescue efforts by qualified personnel.

Reporting: Should a chemical safety incident occur, follow procedures outlined in [Appendix D: Hazardous Materials Emergencies and Spills](#). Report all accidents to your supervisor.

Clean-up: Promptly clean up all small spills using appropriate personal protective equipment and properly containerize and label the resulting waste. Contact EHS & RISK MANAGEMENT for pick up and disposal. Consult (M)SDSs and other safety information sources for specific clean-up recommendations. Contact EHS & RISK MANAGEMENT immediately to clean up large chemical spills or spills of highly toxic chemicals. For detailed information on procedures for accidents, spills and emergencies see [Appendix D](#).

7.2. Avoidance of “Routine” Exposure

Develop and encourage safe work practices. Avoid unnecessary exposure to chemicals by any route and encourage proper personal hygiene (i.e. remove gloves and wash hands prior to leaving laboratory area). Do not smell or taste chemicals. Vent any apparatus that may discharge toxic chemicals (vacuum pumps, distillation columns, ovens, etc.) into local exhaust devices. Inspect gloves and test glove boxes before use. Do not allow release of toxic substances in cold rooms or warm rooms, since these contain recirculated atmospheres. **Use appropriate glove material for the chemical in use.**

7.3. Choice of Chemicals/Waste Minimization

Strive to substitute less hazardous chemicals in place of more hazardous chemicals whenever practical. Use micro-scale lab techniques as often as possible. Share surplus chemicals with colleagues. (see [Appendix M](#) under Waste Minimization/Chemical Surplus). Limit inventory on hand to chemicals and quantities necessary for laboratory activities. Inspect chemical inventories periodically and dispose of outdated chemicals in accordance with the LU Hazardous Waste Policies and Procedures (see [Appendix M: Hazardous Materials Manual](#)). **Maintain an up-to-date inventory of chemicals present, to avoid**

doubling up on materials.

7.4. Shipping and Receiving Hazardous Materials

Shipping and receiving hazardous materials shall be done in accordance with [Appendix C: Hazardous Materials Shipping/Receiving Guide](#). Hazardous materials packages must be inspected at the time of their arrival to ensure that they are not damaged or leaking. Do not accept damaged or leaking packages from delivery companies and notify EHS & RISK MANAGEMENT at (409) 880-8276 if damaged or leaking packages are discovered.

Do not accept hazardous materials packages that are not properly labeled in accordance with Department of Transportation (DOT) regulations. Principal Investigators/Lab Managers should date chemical containers, and enter them into the lab inventory upon receipt, and date them again when first opened.

Gifts or donations of chemicals from off-campus sources must be approved by **EHS & RISK MANAGEMENT** before acceptance.

7.5. Compressed Gas Cylinders

Compressed gas cylinders may present both physical and health hazards. Gases may be oxidizers, flammable, reactive, corrosive, or toxic and these properties must be considered when developing experimental procedures and designing apparatus. Compressed gases, when handled incorrectly, can be very dangerous with a high potential for explosion. Only cylinders designed, constructed, tested, and maintained in accordance with US Department of Transportation (DOT) specifications and regulations shall be permitted to be used. The use of non-DOT conforming cylinders must be evaluated and approved by EHS & RISK MANAGEMENT on a case-by-case basis.

OSHA's general requirements for compressed gas cylinders can be found in [29 CFR 1910.101](#), which incorporates by reference the Compressed Gas Association's Pamphlets C-6-1968, C-8-1962, and P-1-1965. These pamphlets describe the procedures for inspecting, handling, storing, and using compressed gas cylinders. The National Fire Protection Association also provides guidance on the management of cylinders in NFPA 55: Compressed Gases and Cryogenic Fluids Code, which is incorporated by reference into the Uniform Fire Code. Safety procedures that must be followed when handling, storing, and transporting compressed gas cylinders are summarized below:

- Cylinders must be clearly labeled with their contents.
- Anyone working in the same area as a compressed gas should be trained in the hazards presented by the gas.
- Regulators and gas lines must be compatible with the cylinder contents and valve.
- Cylinders must be secured in an upright position by corraling them and securing them to a cart, framework, or other *fixed object* by use of a restraint.
- Cylinders must be stored in a cool, well-ventilated area away from ignition and/or heat sources.



- When not in use, cylinders must always be capped.
- Cylinder carts must be used to transport cylinders, and cylinders must be capped and properly secured during transport.
- Cylinders containing flammable gases must not be stored near oxidizers (minimum 20 ft. separation). This rule also extends to toxic or highly toxic, pyrophoric, unstable reactive, and corrosive gases, and gases with any of the other hazards. Separation can be decreased with a 0.5 hour-rated fire wall.
- Cylinders must not be stored near corrosives.
- Cylinders must be stored away from doors and exits.

All cylinders (new, used, or empty) must be secured at all times. Chains or belts must be used with properly-tightened clamps or wall mounts to secure cylinders that are not otherwise secured on carts, or in cylinder cages. Restraints must be kept tight at all times, with no appreciable amount of slack. Do not store gas cylinders in the hallway. Restrain the cylinder at roughly 2/3 the height of the cylinder, and secure it to an immobile, sturdy surface, as mentioned above.

The use of disposable or lecture size cylinders is strongly discouraged. If special circumstances warrant the use of these types of cylinders, the Principal Investigator/Lab Manager is responsible for contacting **EHS & RISK MANAGEMENT** for disposal of these types of cylinders.

Although cryogenic liquefied gases (e.g. liquid nitrogen) are generally not stored under pressure, laboratory personnel must become familiar with the special hazards associated with the use of these gases. Contact **EHS & RISK MANAGEMENT** for additional information.

7.6. General Laboratory Safety Guidelines

Observe the following basic safety guidelines when working in a laboratory.

Eating, Smoking, etc.

Do not eat, drink, use tobacco products (smoke, chew, dip), chew gum, use cell phones or apply cosmetics in areas where laboratory chemicals are present; remove gloves, wash hands and leave the area before conducting these activities. Do not store food or beverages in refrigerators or glassware that have been used for laboratory operations.

General Housekeeping and Apparel

Keep the work area clean and uncluttered, with chemicals and equipment being properly labeled and stored; clean up the work area upon completion of an operation or at the end of each day. Confine long hair and loose clothing and remove jewelry. Wear appropriate closed toed shoes at all times in the laboratory.



Cleaning Equipment and Glassware

Even after pouring out a hazardous material, it is possible that traces remain, which may react unpredictably with other materials. To minimize the risk of this, it is recommended that any glassware that contained a hazardous material be rinsed three times with a suitable solvent (e.g. water for polar substances, acetone for somewhat polar substances, and hexane for nonpolar substances) after the beaker is visibly clean. The washing should be conducted within a fume hood if the materials within, or expected side reactions with the solvent, may generate a hazardous gas. The wash should be poured into an appropriate hazardous waste container. Since hexanes and acetone are themselves hazardous, this process must be repeated for them (hexanes must be rinsed away with acetone, and acetone with water). Repeat this process until you have the container rinsed thrice with a nonhazardous material.

Handling Equipment and Glassware

Handle and store laboratory glassware with care to avoid damage, and never use damaged glassware. Use extra care with Dewar flasks and other vacuum glass apparatus. Shield or wrap them to contain chemicals and fragments should an implosion occur. Use equipment only for its designed purpose. Decontaminate and properly dispose of damaged/unwanted glassware according to any chemical, biological or radiological hazards that may be present.

Unattended Operations

Leave lights on, place an appropriate sign on the door, include your name and telephone number as well as that of Principal Investigator. Provide for containment of hazardous substances in the event of failure of a utility service to an unattended operation. All unattended operations must be provided with automatic shutoffs to prevent accidents, fires, or explosions.

Working Alone

Avoid working alone in a building. Prior approval from the Principal Investigator or Lab Manager is required before working alone in a laboratory as well as informing the University Police upon entering and leaving the building.

Working alone in a laboratory is prohibited when working with an immediately hazardous material, equipment, or in an area that, if safety procedures fail, could reasonably result in injury (see Working Alone & Laboratory Access Policies).

Children Prohibited

Minor children (under 18 years of age) are not allowed into any chemical, biological or radioactive materials laboratory at LU unless the minor child is participating in a program of study at LU and working in the laboratory is required as part of the course, or the minor child is participating in a supervised program officially sponsored by LU, such as a building tour or field trip. Permission slips/waivers of liability may be required. Refer to the LU policy on [Minors in Research Laboratories or Animal Facilities](#) for additional information. The University's General Counsel may also be contacted for further details.



Planning Operations

The following best practices should be observed during the planning stage for all laboratory operations:

- Develop Standard Operating Procedures (see [Appendix A](#)).
- Seek information and advice about hazards.
- Review all applicable (M)SDSs before handling chemicals.
- Plan appropriate safety procedures.
- Plan positioning of equipment before beginning any new operation.
- Locate emergency supplies and exits.
- Ensure that aisles are clear and kept clear during laboratory operations.
- Verify suitability of any PPE or engineering safeguard to the planned purpose.

Principal Investigators or Lab Managers must approve all new experimental protocols or any significant changes to existing protocols.

Waste Disposal

Standard Operating Procedures (see [Appendix A](#)) for each laboratory must include procedures for waste disposal. Each laboratory generating hazardous waste must have at least one lab manager responsible for ensuring that all waste generators within the lab receive annual Hazardous Waste Awareness and Handling Training. Hazardous wastes must be properly containerized, labeled and stored. Contact EHS & RISK MANAGEMENT for pick up and disposal of hazardous wastes. Hazardous Waste Disposal Procedures for the University are outlined in the **Hazardous Materials Manual** (found in [Appendix M](#)).

Laboratory Contact Information

Each laboratory must have laboratory contact and emergency procedure information posted on the entrance to the lab and by lab telephones, when present. (See [Appendix E](#) – Forms and Checklists for recommended form.) Additional laboratory signage is required for work with biological and radiological materials. (See also, [Biological Safety](#) and [Radiation Safety](#) Manuals.)

Laboratory Security

When authorized laboratory personnel are not present, each laboratory must be kept locked, even if it is only for a short period of time. Depending on the type of work performed in a particular laboratory, it may be prudent to keep that laboratory locked at all times. Laboratory personnel must immediately, and politely, engage unknown individuals discovered in a lab in order to determine their reason for being there. A simple, “May I help you?” should get the dialog started. Immediately report suspicious individuals to University Police. Lab doors must shut during fire evacuations. (See also, Laboratory Access Policy)

8 – EXPOSURE CONTROL MEASURES

Safe work with hazardous chemicals can only be accomplished through the use of proper control measures. Proper control measures include the use of engineering controls, appropriate storage and handling of chemicals, the use of personal protective equipment, and proper use and maintenance of safety equipment.



Carefully implemented control measures can reduce or eliminate the risk of employee exposure to hazardous chemicals.

8.1. Exposure Determination

The Chemical Hygiene Officer or Industrial Hygienist shall initiate air monitoring for any regulated substance if there is reason to believe that the exposure levels for that substance exceed the action level or, in absence of the action level, the OSHA permissible exposure limit (PEL). The PEL is the eight-hour time weighted average concentration of contaminant in air to which a healthy person can be repeatedly exposed without reasonable expectation of adverse health effects. PELs for many chemicals can be found in (M)SDSs, OSHA's "Z Tables" ([29 CFR 1910.1000](#)), and in the [NIOSH Pocket Guide to Chemical Hazards](#).

8.2. Engineering Controls

Engineering controls include proper laboratory design, adequate ventilation, and the use of other safety devices (mechanical pipettes, safety centrifuge cups, etc.). Ventilation is the most common and most important form of engineering control used to reduce exposures to hazardous chemicals. There are two types of ventilation; general ventilation, and local exhaust.

General Ventilation

General ventilation for laboratory operations should be designed such that the laboratory is under a slightly negative pressure relative to other parts of the building. This prevents odors and vapors from leaving the lab. Lab ventilation should be verified by professional engineering analysis. Proper design of laboratory ventilation systems minimizes the possibility of chemical vapors accumulating.

Local Exhaust

Local exhaust ventilation systems are intended to capture an emitted contaminant at or near its source, before the contaminant has the opportunity to disperse into the workplace air. In laboratories, chemical fume hoods are local exhaust devices recommended for use to reduce exposure to hazardous dusts, fumes and vapors. As a rule, the hood shall be used for all chemical procedures involving substances that are volatile and/or have a PEL less than 50 ppm. Hoods should not be used for chemicals that they are not designed to accommodate. Most prominently, Lamar University hoods cannot normally accommodate perchloric acid. The hood sash should be closed or lowered to an appropriate working level to provide protection from chemical splashes and fires and to allow for optimal hood operating efficiency.

Fume hoods are certified annually, or more frequently, if required by the manufacturer, for proper operation by the academic departments. A sticker located above the sash contains the proper sash height, hood face velocity (generally recommended to fall within 100 – 140 linear feet per minute of air), date of inspection and the inspector's initials. The proper sash height is also indicated by a sticker on the side of the fume hood opening. If there are problems with a hood, the Facilities Department and EHS & Risk Management should be notified. A hood is not designed to withstand explosions nor as a means of disposal for volatile chemicals. When using a fume hood, always keep your work at least 6 inches inside the hood face. This simple step can reduce vapor concentrations

at the face of the hood by as much as 90 percent. See the section entitled **Fume Hood Performance** for more on hood usage.

Biological safety cabinets, glove boxes, and isolation rooms also provide local exhaust ventilation. These are usually very specialized pieces of equipment. Biological safety cabinets must be certified for use annually by trained and certified individuals such as manufacturer or distributor representatives. Glove boxes should be pressure tested periodically, per manufacturer's recommendations, to ensure they are functioning properly.

8.3. Personal Protective Equipment

The laboratory environment contains many potential hazards. Most hazards can be reduced or eliminated by substitution and/or engineering controls. Substitution is the reduction or elimination of a hazard by replacing a high hazard material or procedure with a less hazardous one. When hazards cannot be adequately controlled through the use of substitution and/or the implementation of engineering controls, personal protective equipment (PPE) may be required.

PPE issued to laboratory personnel must be appropriate for the task and will depend upon the proper hazard identification and assessment made by the Principal Investigator (PI). Laboratory personnel must understand the use and limitations of the PPE. PPE includes, but is not limited to, laboratory coats and aprons, eye protection (safety glasses, face shields, etc.), and gloves. Laboratory personnel must wear proper PPE when it is required.

Eye/Face Protection

The PI has many responsibilities in regard to eye and face protection, including:

- Assessing the potential for eye/face injuries due to exposure to eye or face hazards from flying particles, molten metal, toxic liquid chemicals, acids or caustic liquids, chemical gases or vapors, or potentially injurious light radiation;
- Training employees on the uses and limitations of PPE;
- Providing the appropriate type of protection required; and
- Ensuring that the appropriate eye/face PPE is available and used by laboratory personnel.

All eye/face protection devices must meet the requirements set forth in the ANSI Z87 standard.

Note: Additional eye/face protection standards should be consulted for welding operations ([29 CFR 1910.133](#)) and for laser use ([ANSI Z136](#)).

When evaluating the appropriate type of eye protection to use, it is important to note that more than one type of protection may be appropriate. Also, multiple layers of eye and face protection may be warranted for higher-hazard operations. During the PPE selection process, the PI should consider the following:

- Safety glasses should be upgraded to splash-resistant chemical goggles whenever pouring liquid chemicals. Chemical goggles offer a much higher degree of eye protection.
- Face shields are not to be worn alone. They must only be used as a secondary means of eye and face protection, with the appropriate primary eye protection worn underneath. For example, chemical goggles should be worn under a face shield while pouring acids.



- Goggles come in many varieties. The right type of goggle must be selected to ensure the appropriate level of eye protection is achieved. For example, vented goggles protect the wearer from flying chips and are appropriate for cutting operations; however, the vents make them less effective as splash protection.

Contact **EHS & RISK MANAGEMENT** for additional information on the assessment of hazards, and the selection, and use of eye/face protection equipment.

Gloves

Gloves play an important role in the safe handling of laboratory materials. Gloves must be comfortable, sufficient in length, and made of material that has the appropriate level of chemical resistance for the task to provide adequate protection. Depending on its intended use, a glove may be designed to provide dexterity, strength, low permeability, resistance to penetration by sharp objects, or protection from temperature changes. Specific information on the properties of glove materials can be found in the manufacturer's permeation guide. See [Appendix K: Glove Selection Chart](#) for additional information.

Respirators

The selection and use of respirators must be done in accordance with [29 CFR§1910.134](#) and [LU's Respiratory Protection Policy](#). Respirators can only be used when it is not possible to minimize or eliminate exposure to a contaminant through other means. All individuals issued respirators must meet the criteria established in the OSHA standard and University Policy. These criteria include medical screening, training, and fit testing. For further information, contact **EHS & RISK MANAGEMENT**.

8.4. Lab Coats & Aprons

General

The following general directions apply to both disposable and reusable lab coats and aprons, used for chemical, biological, and/or radiological protection. All laboratory clothing shall be stored in a sanitary manner in a contamination-free area of the lab. Lab coats and aprons are not to be worn while eating or drinking and should not be worn outside the laboratory except when transporting hazardous materials or moving between labs. The wearing of lab coats, aprons, or other potentially-contaminated personal protective equipment into break areas or lunch rooms is strictly prohibited.

Lab coats and aprons that are contaminated must be handled as little as possible. They must be evaluated by laboratory personnel for laundering or disposal, depending on the nature of the contamination, and bagged or containerized at the location of use. If coats or aprons are visibly wet, they should also be placed in secondary containment to prevent the spread of contamination should the plastic bag or container leak or be otherwise compromised during storage or transport. Lab coats and aprons must not be sorted or rinsed in the location of use since the process can result in the spread of contamination and/or the uncontrolled release of contaminants down the drain. Note: Rinsing areas in labs may also be unsanitary or inadequate for laundering purposes.



Disposable Lab Coats and Aprons

Use of disposable lab coats and aprons whenever practical is strongly encouraged as these coats are low- cost and can be replaced once contaminated or otherwise soiled. Disposable, single-use coats and aprons can be placed in the trash if they have not been contaminated with chemicals, pathogens, or radionuclides.

If contaminated, lab coats and aprons shall be placed in a sealed, leak-proof, labeled plastic bag and segregated by contaminant type – chemical, radiological, or biological. Contact EHS & Risk Management for pickup and disposal of contaminated, disposable lab coats, as you would with any other hazardous waste. Note: Disposable lab coats and aprons shall not be cleaned since the cleaning process can severely degrade the materials of construction, potentially allowing contamination to pass through onto clothing on reuse.

Reusable Lab Coats and Aprons Contaminated with Chemicals

Lab coats and aprons that become contaminated with chemicals must be evaluated on a case-by-case basis. Those that are contaminated with acutely hazardous chemicals or waste shall be considered hazardous waste and must not be laundered or reused. Lab coats and aprons that have been grossly contaminated with non-acutely hazardous waste may also be designated for disposal rather than laundering, depending on the chemical nature of the contaminant(s), since laundering may spread contamination and/or result in discharge of effluent that exceeds local limits. All lab coats and aprons that are designated for management as hazardous waste shall be placed in a sealed, leak-proof, labeled plastic bag, placed in the lab's waste storage area, and picked up by EHS & RISK MANAGEMENT.

Lab coats and aprons that have been contaminated due to incidental contact with non-acutely hazardous chemicals or that have become dirty from regular use can be laundered by a commercial vendor that has expertise in cleaning lab coats, or laundered onsite at an approved facility per the Onsite Lab Coat and Apron Laundering procedures provided at the end of this section. Note: When a department's contaminated laundry is transported off site, the department must ensure compliance with all applicable federal, state, and municipal regulations, including labeling.

FR (Flame Resistant or Flame Retardant) Lab coats must be worn when handling Pyrophoric or extremely flammable (flashpoint <73°F) substances. These Lab coats must be cleaned by a qualified commercial vendor in order to retain the FR properties.

Reusable Lab Coats and Aprons Contaminated with Pathogens

Universal Precautions should be observed for all lab coats and aprons that are contaminated or potentially-contaminated with pathogens. Contaminated lab coats and aprons can be disposed of as biological waste, sent to a commercial vendor that has expertise in cleaning lab coats, or autoclaved, evaluated for reuse, and laundered onsite. Note: Depending on the materials of construction, the coat or apron may not be able to withstand the high temperatures of an autoclave. Also, coats or aprons that also have chemical or radiological contamination should never be autoclaved.

All lab coats and aprons that are designated for management as biological waste shall be placed in a sealed, leak-proof, labeled plastic biological waste bag, placed in the lab's waste storage area, and



picked up by EHS & RISK MANAGEMENT.

When staging contaminated lab coats or aprons for pickup by an outside commercial laundering service, the use of alternatively labeled or color-coded containers is required. Employees must be able to readily recognize the containers as requiring compliance with Universal Precautions. Departments must ensure that employees are provided with proper, color-coded containers that are designated for exclusive use in the transport of contaminated laundry. As with the case of chemicals, when a department's contaminated laundry is transported off site; the department must ensure compliance with all applicable federal, state, and municipal regulations, including labeling.

Biological laboratory lab coats and aprons that are dirty from regular use but otherwise non-contaminated, or those that have undergone successful autoclaving can be laundered at an approved-on site facility per the Onsite Lab Coat and Apron Laundering procedures provided at the end of this section.

Reusable Lab Coats and Aprons Contaminated with Radionuclides

As with the case of chemicals, lab coats and aprons that become contaminated with radionuclides must be evaluated on a case-by-case basis. Lab coats and aprons that become contaminated with long-lived radioisotopes (^3H , ^{14}C , ^{22}Na , ^{51}Cr , ^{45}Ca) shall be placed in designated, dry solids, radioactive waste containers for management as radioactive waste. Lab coats and aprons contaminated with short-lived radioisotopes (^{32}P , ^{33}P , ^{35}S , ^{125}I) shall be segregated from other radioactive waste. Contact the Radiation Safety Officer (409-880-8243) for storage of these items in designated, separate, radioactive material containers where the lab coats will be kept until the radioisotopes have been fully decayed. Once fully decayed, the lab coats can be removed and evaluated for reuse. Note: Never autoclave lab coats that are contaminated or potentially contaminated with radioactive material.

Lab coats and aprons from a laboratory that uses radioactive materials that are not contaminated, including those that have been fully decayed, surveyed, cleared and deemed reusable may be laundered by a commercial service with expertise in laundering laboratory clothing or at an approved onsite laundry facility per the Onsite Lab Coat and Apron Laundering procedures provided at the end of this section.

Onsite Lab Coat and Apron Laundering

Departments and/or laboratories that have their own laundering facilities must ensure that the use of these facilities does not (1) result in the spread of contamination, (2) result in the uncontrolled release of chemical, biological, or radiological contamination to the environment while lab coats or aprons are being transported, or (3) send contamination down the drain that exceeds the City of Beaumont's wastewater treatment facility influent limitations. Refer to the [City of Beaumont Sewer Use Policy Limits](#) and contact EHS & Risk Management for additional information or clarification.

8.5. Proper Storage and Handling of Chemicals

Proper storage of chemicals is important to prevent chemical reactions that may result in fires, explosions or other safety/health hazards. Chemicals must be stored according to chemical group, not simple alphabetical order. Store chemicals of similar hazards and reactivity together. Many chemical



companies provide storage codes for their products in order to assist customers with the proper storage of chemicals. [Appendix J: Storing Chemicals Safely](#) provides additional information regarding storage time limits and chemical incompatibilities. Here are some general rules for safe chemical storage:

- Store chemicals only in secure, well-ventilated areas.
- Chemicals should be stored properly in cabinets or on shelves. Do not store chemicals on the floor or in fume hoods. Make sure all chemicals are securely capped when not in immediate use.
- Shelving units must be stable and secured to the wall (island units must be braced across the top). Shelves should have lips to prevent items from sliding off.
- Keep chemicals pushed back on shelves to prevent them from falling off in the event of accidental tipping. A good rule of thumb is to set bottles back from the edge a distance equal to the height of the bottle when in an upright position.
- Reactive chemicals should be stored on low shelving, preferably in secondary containment in case of leakage.
- Dispose of outdated chemicals. Contact **EHS & Risk Management** to dispose of outdated chemicals.
- Always keep chemicals properly labeled – relabel if a label is becoming faded or has been damaged.
- Make sure labels include the full name of the chemical, clearly written out in English and the proper GHS Pictograms. Do not rely on abbreviations, acronyms, chemical formulas, and chemical structural diagrams as the sole source of information on container labels. Record dates of acquisition, opening, or synthesis, as appropriate, on each chemical's label as well.
- Store large quantities of flammable chemicals in an approved flammable storage cabinet.

Laboratory personnel must always wear proper PPE when handling chemicals, and secondary containment must always be used when transporting chemicals from one location to another to prevent accidental chemical releases.

Flammable Chemical Storage

Flammable liquids generate vapors that can readily ignite and burn in air. The rate at which different liquids produce flammable vapors depends on their vapor pressures and temperatures. These substances should be stored separately from oxidizers and corrosive materials and in an NFPA-compliant flammable storage cabinet. Storage of flammable liquids (including waste) outside approved flammable storage cabinets and safety cans must not exceed 10 gallons per 100 square feet of laboratory space. See *Table I* for storage limitations imposed by OSHA and NFPA.



Table I Flammable and Combustible Liquid Storage Limits for Laboratories¹

Laboratory Unit Class	Flammable or Combustible Liquid Class	Excluding Quantities in Storage Cabinets ² or Safety Cans	Including Quantities in Storage Cabinets ³ or Safety Cans
		Maximum Quantity ³ per 100 sq. ft of Laboratory Unit	Maximum Quantity ³ per 100 sq. ft of Laboratory Unit
A ⁴ (High Hazard)	I	10 gallons	20 gallons
	I, II, and IIIA	20 gallons	40 gallons
B (Intermediate Hazard)	I	5 gallons	10 gallons
	I, II, and IIIA	10 gallons	20 gallons
C (Low Hazard)	I	2 gallons	4 gallons
	I, II, IIIA	4 gallons	8 gallons

¹The information in this table was taken from the NFPA 45 standard on *Fire Protection for Laboratories Using Chemicals*, 1996.

²Only *Approved Storage Cabinets* as defined by NFPA 45 are allowed by **EHS & RISK MANAGEMENT**.

³The maximum quantities of flammable and combustible liquids in Class B and Class C instructional laboratory units shall be 50 percent of those listed.

⁴Class A laboratory units shall not be used as instructional laboratory units.

Corrosive Liquid Storage

Corrosive chemicals include strong acids and bases, dehydrating agents, and oxidizing agents. Inhalation of vapors or mists from these substances can cause severe bronchial irritation. These chemicals also erode the skin and respiratory epithelium and are particularly damaging to the eyes. Corrosive chemicals should be stored in corrosion resistant cabinets and separated from other reagents. Acids should be stored separately from bases, and both should be stored separately from flammables and combustibles. Nitric acid should be stored by itself away from other chemicals whenever possible. **Never store Nitric acid with organic acids** (i.e. Glacial Acetic Acid).

Oxidizing Agents

Oxidizing agents, in addition to their corrosive properties, can present fire and explosion hazards on contact with organic compounds or other oxidizable substances. Strong oxidizing agents (see *Table II*) should be stored and used in glass or other inert containers. Cork and rubber stoppers should not be used with these substances.



Table II Examples of Oxidizing Agents¹

Gases:	Fluorine, Chlorine, Ozone, Nitrous Oxide
Liquids:	Hydrogen Peroxide, Nitric Acid, Perchloric Acid, Bromine, Sulfuric Acid
Solids:	Nitrites, Nitrates, Perchlorates, Peroxides, Chromates, Dichromates, Picrates, Permanganates, Hypochlorites, Bromates, Iodates, Chlorites, Chlorates

¹The information in this table was taken from *Prudent Practices in the Laboratory: Handling and Disposal of Chemicals*. National Academy Press 1995.

Peroxidizable Compounds

Peroxidizable compounds (including ethers) are a group of chemicals which become shock sensitive when they form organic peroxides. This reaction is catalyzed by changes in sunlight, temperature, and pressure. Store these compounds airtight and in their original containers, ideally with an inert gas such as nitrogen in the headspace (the area above the liquid in the bottle). Isolate these chemicals from combustible and oxidizable materials, preferably in a flammable storage cabinet. Always date peroxidizable compounds upon receipt and upon opening. See [Appendix J](#) for more information on the handling, disposal, labeling and storage time limits for peroxidizable compounds.

Highly Reactive (Shock Sensitive) Chemicals

Highly reactive chemicals are inherently unstable and can react in an uncontrolled manner liberating heat and toxic gases, which can lead to explosion. Highly reactive chemicals include shock sensitive chemicals, high-energy oxidizers, and peroxide formers. Before using these materials, safety information should be reviewed to evaluate proper storage, handling, and disposal procedures. Always date highly reactive/shock sensitive chemicals upon receipt and upon opening.

The following additional procedures are recommended for handling reactive chemicals:

- Secure reaction equipment properly.
- Use impact protection (shields and guards) in addition to chemical splash protection (eye protection, gloves, laboratory coat, etc.).
- Handle shock-sensitive chemicals gently to avoid friction, grinding, and impact.

Review [Appendix M](#) for specific examples of shock sensitive chemicals as well as additional safety information.

Toxic Chemical Storage

Toxic chemicals should be stored in accordance with general chemical compatibility guidelines. Highly toxic chemicals that can pose immediate danger to life and health upon container opening



should be stored under lock-and-key. Some examples of these compounds include, but are not limited to, dimethyl mercury ((CH₃)₂Hg), thallium (III) oxide (Tl₂O₃), and hydrofluoric acid (HF).

Crossover Properties

Many chemicals found in the laboratory exhibit properties common to more than one of the previously mentioned groups (for example, ether). For each chemical, one should simultaneously follow the safety guidelines for all applicable hazard groups. Contact **EHS & RISK MANAGEMENT** for additional information about the storage of specific chemicals.

Storage of Chemical in Refrigerators

All refrigerators located in laboratory areas must be clearly marked as to their contents. An inventory list should be posted on the outside of the refrigerator. Refrigerators used for chemical storage must be marked "Chemical Storage Only! No Food!" Flammable chemicals are not to be stored in a refrigerator unless the refrigerator is specifically designed and approved for flammable storage. **Other lab refrigerators should be labeled as "Not Safe For Flammable Storage"**. Refrigerators located in break rooms or lunchrooms, and which are located in the vicinity of laboratories, should be marked "Food Storage Only! No Chemicals!" *Refrigerators in laboratory work areas must not be used for food storage.*

Labeling

All containers (including beakers, vials, flasks, etc.) must be labeled with their chemical content(s) and other relevant information. This includes dilute as well as stock solutions. Whenever possible, chemicals should remain in their original containers with the original labels intact. If a chemical is transferred from its original container, the new container must have the full name of the chemical, written out in English, and appropriate GHS Pictogram, if it is physically possible to fit; if it is not, contact EHS & Risk Management for clarification. Damaged or faded labels must be replaced before becoming illegible. Additional information on labeling requirements can be found in the University [Hazard Communication Program Manual](#).

Moving Chemicals on Campus

Whenever chemicals are moved between labs or storage rooms in the same building, between buildings, or even across campus, the use of secondary containment or overpacking is required as an added safety precaution. Both secondary containment and overpacking help mitigate the adverse effects of a spill or an in-transit container failure by reducing the likelihood of environmental releases and the probability and severity of exposure to harmful chemicals. For those chemicals which are immediately dangerous to life and health (IDLH) when spilled, overpacking is required. When practical, additional secondary containment may also be used in conjunction with overpacking to provide an added level of protection.

Note: For the purposes of this section, secondary containment refers to open top bins, pails, containers, trays, etc. that are moved in an upright position. Overpacking refers to closed top/encapsulating packaging that can hold its contents even if tipped over.



Secondary Containment

The form of secondary containment that is most widely used at the University consists of durable plastic bins. This baseline level of containment is required when moving liquid chemicals and is strongly recommended when moving solid chemicals as well. Solid chemicals may also be moved in cardboard boxes of rigid construction that have completely closed and properly sealed bottoms. For compressed gases contained in lecture bottles, plastic pails serve as an adequate baseline level of containment. Secondary containment is not used for large DOT-approved compressed gas cylinders. Guidance for transporting DOT cylinders can be found in the Compressed Gas Cylinder Section of this CHP.

In all cases, the secondary containment selected must be constructed of material that is compatible with the chemical(s) being moved. The secondary containment must also be strong enough to hold all containers without excessive flexure and must have enough volume to hold the contents of all containers without overflowing in the event of container failure. As needed, spill pads, cardboard inserts, or bubble wrap can be used to prevent bottles from bumping together while being moved. This practice helps minimize the potential for bottle breakage.

Overpacking

Overpacking is the practice of placing a chemical container within a larger, often padded, sealable container to increase the level of protection in the event of a spill or container failure while being moved. The original DOT-compliant packaging, used to ship the chemical on initial purchase, can always be used as an overpack as long as the outer packaging is in good condition and includes all original inner packaging materials, such as plastic liners, absorbent materials, foam padding, etc. A basic overpack consisting of a larger sealable container, of construction compatible with the chemical being moved, and packed with spill pads, is easily made and effective for most chemicals when the original vendor packaging is unavailable, incomplete, or damaged.

In order to better understand when overpacking is required, the degree of severity of the hazard posed while moving a chemical must be fully understood. The degree of severity of a hazard is a function of a chemical's hazard classification, amount being moved, and relative concentration in mixtures or solutions. Note: Consideration must also be given to the route traveled, weather conditions (if moving chemicals outdoors between buildings), and potential for the presence of other people along your chosen path. Since these three factors are situation and location-specific, they are left to the responsible individual, tasked with moving chemicals, to evaluate on a case-by-case basis.

A decision tree has been included as **Appendix K** of this CHP. This tool can be used to determine the specific type of overpacking needed for the different hazard categories. If you have any questions or require further assistance, contact EHS & RISK MANAGEMENT.

Hazard Classification

The safety data sheet (SDS) for a chemical can be a valuable tool in evaluating the need for overpacking. Section 2, "Hazards Identification," of GHS-compliant SDSs provides the GHS hazard classifications and category numbers for all pertinent chemical(s) of concern. Under the GHS system, the lower the hazard category number, the higher the hazard. As a general rule of thumb, as the GHS hazard number decreases, the need for additional care while moving chemicals and the necessity for



overpacking both increase. This is the opposite of the pattern for the NFPA hazard numbers, which are frequently, but optionally, included in SDSs. Any chemical that is IDLH: explosive/shock sensitive, pyrophoric, water reactive or a strong lachrymator requires overpacking. Those chemicals that have a GHS hazard category of 1 for the following hazard classifications are also considered IDLH and require overpacking:

- Acute toxicity (any route – inhalation, skin absorption, ingestion, or injection)
 - Skin corrosion
 - Serious Eye Damage

For those chemicals that are GHS hazard category of 2 or 3, overpacking may be appropriate as an added level of protection beyond the baseline practice of using secondary containment. This determination needs to be made on a case-by-case basis and depends on the amount being moved and concentration. GHS hazard category 4 or 5 chemicals do not typically require overpacking; however, they can be overpacked, for added protection, at the discretion of the responsible decision maker, principal investigator, or lab manager.

Amount Being Moved

The amount of chemical being moved can also have an impact on the need for overpacking. Generally, moderate hazard chemicals (with a GHS hazard category of 2 or 3) will not require overpacking if moved in limited quantities, as long as secondary containment is used. If larger amounts of chemicals are to be moved, overpacking should be considered to increase the overall level of protection.

A good example in considering amount as a deciding factor can be found with a chemical such as hexane. Hexane has a hazard category of 2 or 3 for all relevant GHS hazard classifications. When a small bottle of hexane is to be moved, secondary containment is usually adequate. When several 4-liter bottles of hexane are to be moved, overpacking is strongly recommended. In this case, the shipper's original packaging, or a liquid tight container(s) padded with spill pads would both be appropriate.

Concentration

The concentration of a chemical in a solution also plays a significant role in determining the need for overpacking. For those chemicals with a GHS hazard category of 1 that are in solution, concentration is almost directly proportional with the need for overpacking, *i.e.* as concentration increases, so does the necessity of overpacking prior to moving chemicals from place-to-place.

A classic example of how concentration affects the need for overpacking can be found with a chemical such as hydrochloric acid (HCl). Fuming HCl (>37% by volume) has a hazard category of 1 for both serious eye damage and skin corrosion. When the concentration is decreased to 0.1M, the skin corrosion hazard significantly decreases and the hazard category of 1 only remains for serious eye damage. When HCl concentration is further reduced to 0.01M, HCl no longer has a hazard category of 1 for any hazard classification. Fuming HCl should always be overpacked, in the shipper's original packaging or wrapped in spill pads and placed in a larger sealable jar of compatible construction, when moved. The dilute 0.01M HCl solution would require no overpacking and can be



moved like any other low- to moderate-hazard liquid in a plastic secondary containment bin.

Conclusion

The table below is provided as a general guide to better understand when secondary containment and overpacking should be used. Contact EHS & RISK MANAGEMENT if further assistance is required.

Tends toward secondary containment	Tends toward overpacking
Higher GHS hazard number	Lower GHS hazard number
Low Concentration	High Concentration
Small Amount	Large Amount
Lower NFPA hazard number	Higher NFPA hazard number

8.6. Shipping of Hazardous Chemicals

To assure the safe transport of hazardous materials, the University *must* comply with the United States DOT Hazardous Materials Regulations ([49 CFR §171-180](#)). These regulations cover the shipping and transport of hazardous materials such as infectious substances, toxins, flammables, and explosives. They also contain specific packaging and labeling requirements, and require that all individuals who ship hazardous materials be trained in the proper packaging, labeling, and shipping of such goods.

Hazardous Materials are defined as, “substances or materials that are capable of posing a significant risk to health, safety, or property when transported.” University employees may not be involved in the shipping of hazardous materials, *unless* they have received training, which enables them to properly pack and label hazardous materials and to correctly complete the required shipping papers. Laboratories shipping hazardous chemicals must also provide a (Material) Safety Data Sheet to outside entities who will receive the hazardous chemicals. Contact EHS & RISK MANAGEMENT for assistance in shipping hazardous materials off campus, or to obtain the required training. (See [Appendix C: Hazardous Materials Shipping/Receiving Guide](#)).

8.7. Safety Equipment

In most cases, the following safety items should be readily available in laboratories: fire extinguishers, eyewash/safety showers, spill kits/absorbents, first aid kits, and a telephone with emergency numbers posted on it. Consult EHS & RISK MANAGEMENT for assistance in determining safety equipment needs for a particular laboratory.

Annual maintenance inspections on fire extinguishers are performed by a licensed fire extinguisher service contractor. Discharged, overcharged, or missing fire extinguishers need to be reported

immediately to EHS & Risk Management. Eyewash/safety showers should be flushed weekly, with date and tester's initials recorded in an inspection log, by laboratory personnel. Eyewash/safety showers are inspected annually by EHS & Risk Management. In order to verify operation and accessibility, laboratory personnel should check all other safety equipment at least once a week as well. Fume hoods are inspected annually, or more frequently (depending on manufacturer recommendations).

Malfunctioning eyewash/safety showers and fume hoods should be reported immediately to Facilities. If the safety equipment is not repaired promptly, please call EHS & RISK MANAGEMENT. Laboratory operations should be restricted until safety equipment is repaired; no chemical work is to be performed in a malfunctioning fume hood.

Spill Kits and First Aid Kits are to be maintained by individual laboratories or departments. Minimum equipment requirements for spill kits can be found in [Appendix D: Hazardous Materials Emergencies and Spills](#). Emergency contact numbers can also be found in Appendix G.

9 – FUME HOODS

The fume hood is one of the primary safety engineering controls in the laboratory. **EHS & Risk Management** will (1) maintain records of fume hoods annual inspection, (2) monitor the preventive maintenance program for the fume hoods and (3) coordinate the approval and placement of new (or used) fume hoods in the laboratory. The purpose of the fume hood is to remove toxic fumes or contaminants from the breathing zone of the user. There are two basic categories of fume hoods: *General Purpose* and *Special Purpose*. Diagrams outlining the general characteristics of fume hoods can be found in [Appendix G: Diagrams of Local Exhaust Devices](#).

9.1. General Purpose Hoods

These hoods are used for laboratory work with materials that do not require special handling procedures. A general-purpose fume hood can be one of four types: (1) Conventional Hood, the basic hood with a movable sash and baffle. This hood is generally the least expensive and its performance depends mainly on the position of the sash. (2) By-Pass Hood, designed to allow some exhaust air to "by-pass" the face of the hood even when the sash is closed. It is designed for use with sensitive and fragile apparatus and/or instruments. (3) Auxiliary Air Hood, designed to introduce outside air into the hood and limit the amount of room air that is exhausted. (4) Variable Air Volume (VAV) Hood, designed to regulate the hood exhaust and keep the air velocity at a predetermined level.

9.2. Special Purpose Hoods

Certain research activities involve the use of substances that can create dangerous conditions or have clearly defined health hazards. These activities will require specially designed fume hoods to deal with these unique conditions. The most common special purpose fume hoods are perchloric acid and radioisotope fume hoods.

Perchloric Acid Fume Hoods

Procedures with perchloric acid must never be done in a regular fume hood. Special perchloric acid hoods must be used, except in the case of the infrequent use of small quantities of perchloric acid. In this case, a regular fume hood may be used; however, perchloric acid vapor must be trapped and scrubbed prior to release.



Perchloric acid hoods are generally made of corrosion-resistant materials (stainless steel), and are equipped with a water wash down mechanism in the ductwork. Perchloric acid fume hoods must be clearly labeled and used only for perchloric acid or other mineral acids, such as nitric, hydrochloric, and hydrofluoric. **No organic solvents should be stored or used in these hoods.** When perchloric acid is heated above ambient temperature, vapor is formed which can condense in the ductwork and form explosive perchlorates. After each use, the fume hood operator shall wash down the hood and ductwork with water.

Radioisotope Fume Hoods

Any research activity involving volatile radionuclides must be done in a fume hood appropriate for such activities and must meet the requirements set forth by the LU Radiation Safety Officer (RSO). These requirements include, but are not limited to, the following:

- Certification before procedures begin and at routine intervals thereafter, not to exceed one year.
- Establishment of a minimum flow rate of 100 linear feet per minute (lfpm) across the sash opening of the fume hood with a minimum face area (the region between the sash level and the bottom airfoil-see diagram in *Appendix J*) of four-square feet.
- Operation twenty-four hours per day, 365 days per year for those hoods used with tritium or radioiodine.
- Thyroid bioassays are required for individuals working with volatile I125 in quantities greater than 1mCi.

Maintenance of a Use Log for each radioisotope fume hood is required to assure that the established release limits are not exceeded.

General Safety Practices for Fume Hoods

- Fume hoods are *not* designed for storage. Items (equipment, chemicals, etc.) within the fume hood should be minimized as they can reduce fume hood performance. Remove all items not required for procedures in progress.
- Fume hoods should be equipped with “Magnehelic” gauges or flow meters with low flow alarms to ensure that the hoods are functioning properly. In the absence of gauges or meters, a convenient test method is to use a tissue paper streamer attached to the bottom of the sash.
- All work should be at least six inches behind the plane of the face (sash opening) of a fume hood.
- Any items within a hood must not obstruct the baffle openings or impede airflow at the face of the fume hood.



- Fume hoods should be operated with sashes lowered whenever possible, and sashes as low as possible.
- Fume hood baffles are set to exhaust equally from the top, middle, and bottom zones of the hood. Baffle adjustments should only be made after consultation with EHS & RISK MANAGEMENT.
- Fume hoods may fail for a variety of reasons. Lab personnel should have a contingency plan for hood failure to prevent development of hazardous conditions, and to avoid interruptions in laboratory use.
- Instruments stored in the fume hood should be stored on elevated platforms where possible, giving at least 2 inches of free space; this minimizes disruption to airflow.
- Power strips should not be set up within a hood, especially if flammable vapors are known to be present. Power strips introduce a high probability of sparks, which must be avoided in flammable atmospheres.

10 – BIOSAFETY CABINETS AND LAMINAR FLOW HOODS

10.1. Biosafety Cabinets

The Biological Safety Cabinet (BSC) is another primary engineering control in the laboratory. It is commonly used as a containment and protection device in laboratories working with biological agents. The major functional element of a BSC is its ability to create a near-sterile environment through the use of High Efficiency Particulate Air (HEPA) filters. The size, location, and placement of these filters will determine the class and function of a biological safety cabinet.

There are three different classes of BSCs which are not directly related to the Biological Safety Levels (BSLs) required for the microbiological agent being used. Generally, Class I and Class II cabinets can be used for work at BSLs 1 to 3. Class III cabinets are usually reserved for work at BSL4, although a Class II cabinet can be used at this level if the appropriate personal protective equipment is used.

Class I Biosafety Cabinet

A ventilated cabinet for personnel and environmental protection, with non-recirculated inward airflow away from the user. The cabinet exhaust air is HEPA filtered before it is discharged to the outside atmosphere. This cabinet resembles a chemical fume hood with a filtered exhaust and is suitable for work with low and moderate risk biological agents where no product protection is required.

Class II Biosafety Cabinet

A ventilated cabinet for personnel, product and environmental protection having (1) an open front with inward airflow for user protection, (2) downward HEPA-filtered; laminar airflow for product protection, and (3) HEPA- filtered exhausted air for environmental protection. Class II cabinets are suitable for low- and moderate-risk biological agents.



There are four recognized types of Class II biosafety cabinets that are widely used. These are Class II types: A1, B1, B2, and B3. The nature of the particular research operation, the characteristics of a laboratory's exhaust system, and the mandated regulations will determine which type of Class II cabinet can be used. Contact **EHS & RISK MANAGEMENT** for more specific information.

Class III Biosafety Cabinet

A totally enclosed ventilated cabinet of gas-tight construction. Operations in the cabinet are conducted through attached rubber gloves. The cabinet is maintained under negative air pressure of at least 0.5 inches (12.7 mm) water gauge. Supply air is drawn into the cabinet through HEPA filters. The exhaust air is treated by double HEPA filtration. Class III cabinets are suitable for high-risk biological agents and are accompanied by auxiliary safety equipment.

10.2. Laminar Flow Hoods

The term "laminar flow" describes the air purifying action of these hoods because they provide a directed, non-mixing air stream through a HEPA filter. They can also be called "clean benches" because they provide a near-sterile work area. **However these hoods do not provide protection to the user from contamination and, in fact, can expose the worker to aerosols of allergenic or infectious materials.** Researchers therefore must not confuse these hoods with biological safety cabinets. These hoods must not be used for microbiological work with potential pathogens.

Please consult [Appendix G](#) for diagrams of the basic components of laminar flow hoods and biosafety cabinets.

10.3. Materials, Designs and Construction

All materials, designs and construction of BSCs and laminar flow hoods shall abide by the **National Sanitation Foundation (NSF) Standard 49**.

10.4. Performance, Inspection and Certification

Every new BSC must be performance tested by the manufacturer according to the requirements listed in the **NSF Standard**. BSCs convertible from one type to another should be performance tested in each mode. Field certification by authorized individuals or companies should include, but not be limited to, the following testing procedures (described in **NSF Standard 49**):

- Soap Bubble/Halogen Leak
- HEPA Filter Leak
- Velocity Profile
- Vibration sensitivity
- Noise level
- Airflow Smoke Patterns

In addition, each BSC must have a certificate of inspection that should include, but not be limited to, the date of certification, the name of the person who performed the inspection, and the date for the next inspection. **Certification of biosafety cabinets must be done annually, whenever relocated, or if**

a problem is suspected.

Since laminar flow hoods are not used to provide protection to the user, these devices should be certified annually to prevent product contamination.

11 – LOCAL EXHAUST ENCLOSURES AND SNORKELS

Local exhaust enclosures and snorkels are only appropriate for use with low-hazard materials. These devices are not an appropriate substitute for fume hoods or biosafety cabinets, which have significantly higher capture efficiencies. Use of local exhaust enclosures or snorkels with moderate- to high-hazard materials can result in serious injury or death.

Local exhaust enclosures and snorkels may be used to help an already-effective general ventilation system achieve the following:

- Control of nuisance-level dust, fume, and vapor in labs and other workspaces
- Enhanced removal of low-hazard airborne contaminants
- Increased worker comfort

Contact EHS & RISK MANAGEMENT if you require assistance in determining the suitability of local exhaust enclosures or snorkels for your specific application.

12 – EMPLOYEE INFORMATION AND TRAINING

An essential component of the Chemical Hygiene Plan (CHP) is providing information and training to all laboratory workers. This information and training will ensure that laboratory workers are aware of the hazards posed by chemicals in their work areas and how to protect themselves from these hazards.

All employees will be informed and trained about the hazards in the work area at the time of initial assignment and prior to work involving new exposure situations. Refresher training will occur annually.

12.1. Employee Information

Laboratory workers will be informed of, and provided access to the following:

1. Contents and appendices of the "OSHA Lab Standard" ([29CFR§1910.1450](#)).
2. Contents and appendices of the CHP.
3. Mandatory and recommended exposure limits for hazardous chemicals.
4. The signs and symptoms associated with exposures to hazardous chemicals.
5. The location and availability of safety reference materials, including (M)SDSs, for hazardous chemicals.



12.2. Employee Training

The *OSHA Laboratory Standard* requires that training be provided to all employees working in laboratories at the time of initial assignment to a work area where hazardous chemicals are present and prior to assignments involving new exposure situations. The CHP applies this standard to all individuals working in laboratories at Lamar University, with the exception of undergraduate students attending class in non-research laboratories (See note below). It is the responsibility of all lab personnel to attend and stay current with *Laboratory Safety & Chemical Waste Management Training* provided by **EHS & Risk Management** and any job-specific training provided by departments, principal investigators, laboratory/facility managers, or other qualified individuals.

Note: Undergraduate students enrolled in laboratory courses in teaching labs receive training through their instructor which is documented by the department.

Initial Safety Training

All individuals working in labs, including principal investigators, laboratory/facility managers, lab workers, and other personnel must attend the *Initial Laboratory Safety & Chemical Waste Management Training* provided by **EHS & Risk Management** prior to **work in laboratories**. The training covers:

- The contents and location of the *OSHA Laboratory Standard*;
- The location and details of the *Chemical Hygiene Plan*;
- The permissible exposure limits for OSHA regulated substances or recommended exposure limits;
- Signs and symptoms associated with exposures to hazardous chemicals;
- The location and availability of known reference material on the hazards, safe handling, storage, and disposal of hazardous chemicals;
- Methods and observations that may be used to detect the presence or release of a hazardous chemical;
- The physical and health hazards of chemicals in the work area; and
- Appropriate work practices, emergency procedures, and personal protective equipment to be used to protect individuals from hazards in laboratories.

Annual Refresher Training

Refresher training provided by **EHS & Risk Management** must be completed every year by principal investigators, laboratory/facility managers, lab workers, and other individuals working in labs. The training is required to ensure that all individuals working in labs are up-to-date with current federal and state regulations and University policies regarding safety. The refresher training course is offered through EHS.

Laboratory-Specific Training

In addition to training provided by **EHS & Risk Management**, laboratory-specific training must be

provided by departments, principal investigators, or laboratory/facility managers on the specific hazards of chemicals, equipment, or operations unique to each laboratory. Examples of laboratory-specific training include, but are not limited to:

- Use of cryogenic liquids;
- Safety protocols for use of equipment that present health and/or physical hazards to lab personnel (e.g., impact, cuts/penetration, harmful dusts/vapors, noise, etc.);
- Procedures using highly reactive or explosive chemicals (e.g., pyrophoric, water-reactive, etc.); and
- Emergency procedures.

Laboratory-specific training must take place prior to involvement with the chemical, equipment, or operation. [Documentation](#) of the training, including the content, training date, and signatures of both the trainee and trainer, is required by TAC Title 25, section 295.7(e).

12.3. Information and Training Responsibilities

To satisfy the information and training requirements outlined above, laboratory workers must receive Laboratory Safety and Chemical Waste Management training. EHS & RISK MANAGEMENT will provide these trainings to departments upon request and as otherwise scheduled. EHS & RISK MANAGEMENT will document and maintain records of such training and assist departments in tracking their refresher training needs.

Departments must identify laboratory workers who require training and ensure workers attend training sessions, including refresher training. Principal investigators and lab managers must also provide on-the-job, lab specific safety training to laboratory workers.

13 – ACTIVITIES REQUIRING PRIOR APPROVAL

In order to protect the health and safety of laboratory employees, building occupants and the community at large, certain laboratory activities will require prior approval from the designated approval body. *Table III* provides a summary of activities and the bodies within the University responsible for granting approvals for those activities.

Table III Activities and Approving Bodies

Activity	Approving Body
Research grant proposals involving: hazardous chemicals ^A , radioisotopes, lasers	ORSP, EHS & RISK MANAGEMENT
Research involving: human/primate blood, tissues, human, animal and plant pathogens, and recombinant DNA. ^A	Institutional Biological Safety Committee (IBC), Institutional Review Board (IRB)

The use of laboratory animals ^B	Institutional Animal Care and Use Committee (IACUC)
New experimental protocol procedures	Principal Investigator, Lab Manager
Change(s) to existing protocol procedures	Principal investigator, Lab Manager
Unattended operations	Principal investigator, Lab Manager
Working alone in the laboratory ^C	Principal investigator, Lab Manager

^AResearch grant proposals will be used to receive notice of these activities.

^BAnimal Care and Use Committee reviews work when the Principal Investigator applies.

^CProhibited activity: A laboratory worker may not work alone in a laboratory while working with substances of unknown or high toxicity.

14 – MEDICAL CONSULTATIONS/EXAMINATIONS

Employees should contact **EHS & Risk Management** whenever there is a suspected exposure to or significant spill of a hazardous chemical in the laboratory. All accidents, injuries, or incidents must be reported to the supervisor or other person in charge. Chemical safety incidents and injuries resulting in the need for first aid, medical attention, or lost work-time must be documented. Persons responsible for the affected individual(s) must complete the appropriate report. (See University Accident Reporting Procedures.)

If in the course of an exposure investigation by **EHS & Risk Management** monitoring reveals an exposure level routinely above the action level (or, in the absence of an action level, permissible exposure level, “PEL”), as prescribed by the [29 CFR 1910](#) standard that applies to the substance being investigated, then medical surveillance will be established for the affected employee.

Employees will also be provided the opportunity for a medical consultation in the event of a spill, leak, or other potential hazardous exposure occurrence. Such consultation will be used to determine the need for a medical examination. Some of the chemicals used in the laboratory are OSHA regulated and have exposure monitoring and medical surveillance requirements. These requirements are activated when the concentrations of these chemicals meet or exceed exposure levels determined by OSHA.

All consultations/examinations will be conducted or supervised by a licensed physician. These consultations and/or examinations will be provided to the employee at no cost. The employee will be directed to an appropriate medical facility by the University’s Managed Care Provider as required by State Worker’s Compensation requirements.

In cases where laboratory employees seek medical attention for possible overexposure to hazardous chemicals, the Principal Investigator, supervisor, or lab manager must provide the following information to the attending physician:

1. The identity of the hazardous chemical(s) to which the employee may have been exposed;
2. A description of the conditions under which the exposure occurred including quantitative exposure data, if available; and
3. A description of the signs and symptoms of exposure that the employee is experiencing, if any.

If at all possible, a copy of the (Material) Safety Data Sheet(s) for the chemical(s) involved should also be given to the physician. All incidents of overexposure must be fully documented (see [University Accident Reporting](#)

[Procedures](#)).

For any consultation/examination provided under this program, the person responsible for the employee must ensure that the attending physician provides a written opinion regarding the case to **EHS & Risk Management**. These medical documents shall be stored in a locked file cabinet in a room that is also locked when unoccupied. The written opinion must include the following:

1. Any recommendations for further medical follow-up;
2. The results of the medical examination and any associated tests;
3. Any medical condition which may be revealed in the course of the examination which may place the employee at increased risk as a result of exposure to a hazardous chemical found in the workplace; and
4. A statement that the employee has been informed by the physician of the results of the consultation or medical examination and any medical condition that may require further examination or treatment.

The written opinion must not reveal specific findings or diagnoses that are unrelated to the occupational exposure.

Any written opinion from a physician will be treated as confidential medical records and will not be released to third parties without the prior written consent of the employee. Any releases will be logged for tracking purposes. The log will indicate where health records were sent, even if a copy is released to the employee by **EHS & RISK MANAGEMENT**.

15 – PARTICULARLY HAZARDOUS SUBSTANCES

Additional protective measures must be implemented in areas where OSHA "select carcinogens," reproductive toxins, and substances with a high degree of acute toxicity are used. **The Principal Investigator (PI) bears the ultimate responsibility for the safe use of particularly hazardous chemicals in the laboratory.** Researchers must create a *Designated Area* (see definition in the [Appendix F: Glossary](#)) in the laboratory that is physically separated and visually labeled with appropriate warnings. Access to the Designated Area must be strictly controlled. Engineering controls (such as fume hoods and biosafety cabinets) must also be located in this Area. Some additional measures to be followed include:

- Abiding by good industrial/chemical hygiene practices (i.e., no eating drinking or tobacco products, wash hands, use of proper PPE, etc.).
- Properly handling and storing waste.
- Using appropriate procedures for decontamination.

The PI using particularly hazardous substances will be responsible for submitting a Standard Operating Procedure (SOP) to **EHS & RISK MANAGEMENT** for review and approval before the "Designated Area" may

become active. The SOP must outline the methods that will be used, the proper handling of chemicals in the “Designated Area” and access restrictions to the area. Researchers should consult the SOP information described in [Appendix A](#) of this document to complete their SOPs. Contact **EHS & RISK MANAGEMENT** with additional questions or concerns.

15.1. Guidelines for Handling Some Specific Hazardous Chemicals

The guidelines that follow, taken from [Appendix A](#) of the OSHA Lab Standard ([29 CFR§1910.1450](#)), should be adhered to when working with hazardous chemicals of a specific nature. For additional information on the handling, storage or disposal of any of these chemicals, contact **EHS & RISK MANAGEMENT**.

Allergens and Embryotoxins

Allergens (diazomethane, isocyanates, and dichromate’s) can produce varying degrees of symptoms in the body depending upon individual susceptibility. Lab workers should wear suitable PPE (**suitable** gloves, lab coats, safety glasses, respirators, etc.) to prevent hand contact with allergens or substances of unknown allergenic activity.

Embryotoxins (organomercurials, lead compounds, formamide) can have degenerative and toxic effects on developing embryos. Women of childbearing age must handle these substances only in a glove box or hood with satisfactory performance. They must also use appropriate protective apparel (**suitable** gloves, lab coats, etc.) to prevent skin contact.

In addition to these guidelines, the following practices should be instituted when working with allergens and embryotoxins:

- Review the use of these materials with the research supervisor. Review procedures annually or whenever a procedural change is made.
- Store these substances in an unbreakable secondary container, properly labeled, and in an area that is secured (capable of being locked) and adequately ventilated.
- Notify supervisors of all incidents of exposure or spills. Consult a qualified physician when appropriate.

Chemicals of Moderate Chronic or High Acute Toxicity

Certain chemicals have been identified as causing acute and/or chronic health effects. Substances of high acute toxicity cause *immediate* health effects at very low concentrations. Some examples of chemicals with high acute toxicity include the gases hydrogen cyanide, phosgene, and arsine. Substances that have moderate chronic toxicity may cause adverse health effects after repeated exposure over a period of time. These may include carcinogens, teratogens, mutagens, and sensitizers. These supplemental rules should be followed in addition to those for allergens and embryotoxins:

- *Aim:* To minimize exposure to these toxic substances by any route using all reasonable



precautions.

- *Applicability:* These precautions are appropriate for substances with moderate chronic or high acute toxicity.
- *Location:* Use and store these substances only in areas of restricted access with special warning signs.
- *Containment:* Always use a hood (previously evaluated to confirm adequate performance with a face velocity of at least 100 linear feet per minute) or other containment device for procedures which may result in the generation of aerosols or vapors. Trap released vapors to prevent their discharge.
- *Personal protection:* Avoid skin contact by use of **suitable** gloves and long sleeves (and other protective apparel as identified in the (M)SDS or other safety document). Always wash hands and arms immediately after working with these materials.
- *Records:* Maintain records of the amounts of these materials on hand, amounts used, and the names of the workers involved.
- *Prevention of spills and accidents:* Be prepared for accidents and spills. Assure that at least two people are present at all times if a compound in use is highly toxic or of unknown toxicity. Store breakable containers of these substances in chemical resistant trays. Work (including instrumentation areas) and storage areas should be covered with removable, absorbent, plastic backed paper.
 - If a major spill occurs outside the hood, evacuate the area. Contact **EHS & RISK MANAGEMENT** as soon as possible. Cleanup personnel must wear suitable protective apparel and equipment.
- *Waste:* Thoroughly decontaminate/dispose of containers, labware, and contaminated clothing or shoes in accordance with directions from **EHS & RISK MANAGEMENT**. Store contaminated waste in closed, properly labeled, impervious containers. Ensure that absorbent material is used to prevent breaking of containers and to absorb any leakage. All materials used must be compatible with the chemicals in the container.

Chemicals of High Chronic Toxicity

These chemicals can produce severe chronic effects in very low doses. Some examples include dimethylmercury and nickel carbonyl, benzo-a-pyrene, and N-nitrosodiethylamine.

Further supplemental rules to be followed, in addition to all those mentioned above, for work with substances of known high chronic toxicity (in quantities above a few milligrams to a few grams, depending on the substance as identified in a (M)SDS or other safety document, include the following:

- *Access:* Conduct all transfers and work with these substances in a “Designated Area.” A



Designated Area is a restricted access hood, glove box, or portion of a lab, designated for use of highly toxic substances. Make sure all people with access are aware of the substances being used and of the necessary precautions.

- *Approvals:* Prepare a plan for the use and disposal of these materials, and obtain **EHS & RISK MANAGEMENT** approval.
- *Non-contamination/Decontamination:* Protect vacuum pumps against contamination by scrubbers or HEPA filters and vent them into the hood. Decontaminate vacuum pumps or other contaminated equipment, including glassware, in the hood before removing them from the Designated Area.
 - Decontaminate the Designated Area before normal work is resumed there, based on guidance from **EHS & RISK MANAGEMENT**, (M)SDS, and/or other sources of information.
- *Exiting:* On leaving a Designated Area, remove any protective apparel (placing it in an appropriate, labeled container) and thoroughly wash hands, forearms, face, and neck.
- *Housekeeping:* Use a wet mop or a vacuum cleaner equipped with a HEPA filter. Avoid dry sweeping powder if the substance was toxic.
- *Medical surveillance:* If using toxicologically significant quantities (as identified by (M)SDS or other source of safety information) on a regular basis (e.g. 3 times per week), consult a qualified physician concerning regular medical surveillance. If medical surveillance is recommended, consult with **EHS & RISK MANAGEMENT**.
- *Records:* Keep accurate records of the amounts of these substances stored and used, the dates of use, names of users, and disposal records.
- *Signs and labels:* Assure that the Designated Area is conspicuously marked with warning and restricted access signs. Keep all containers appropriately labeled with chemical name and hazard, i.e. "Toxic or Poison."
- *Spills:* Assure that contingency plans, equipment, and materials to minimize exposures of people and property in case of accident are available.
- *Storage:* Store containers of these chemicals only in a ventilated, limited access area in appropriately labeled, unbreakable, chemically resistant, secondary containers.
- *Glove boxes:* For a negative pressure glove box, ventilation rate must be at least 2 volume changes/hour and pressure at least 0.5 inches of water (gauge). For a positive pressure glove box, thoroughly check for leaks before each use. In either case, trap the exit gases or filter them through a HEPA filter and then release them into the hood exhaust. HEPA filters must be evaluated and replaced as necessary by competent laboratory staff. Filters must be disposed of in accordance with hazardous waste regulations. Contact **EHS & RISK**



MANAGEMENT for additional information.

- *Waste:* Use chemical decontamination whenever possible; ensure that containers of contaminated waste (including washings from contaminated flasks) are transferred from the Designated Area in a secondary container under the supervision of authorized personnel.

Working with Perchloric Acid

Perchloric acid solutions shall not be evaporated or heated unless the process takes place in a designated perchloric acid fume hood. These special fume hoods are designed in such a way as to allow systematic wash downs with water after using perchloric acid. The evaporation of perchloric acid leads to the formation of highly explosive anhydrous perchloric acid being deposited on the surfaces of ducts. Additionally, evaporated perchloric acid can form equally explosive metallic perchlorate compounds in ductwork.

LU laboratories lack fume hoods specifically designed for the use of perchloric acid; therefore, use of perchloric acid, when solutions are evaporated or heated, is not permitted, with one exception. In the case of infrequent use of small quantities of perchloric acid, hoods not specifically designed for use with perchloric acid may be permitted to be used if the vapors are trapped and scrubbed prior to release into the hood. Notify EHS & RISK MANAGEMENT before performing this work.

Conducting Procedures with Hydrofluoric Acid

Hydrofluoric acid (HF) is a corrosive material that is dangerous even at low concentrations (50-250ppm) and brief exposure times. Skin contact causes serious skin burns which may not be immediately apparent or painful since HF interferes with nerve function, initially blocking pain. Symptoms may be delayed 8 hours or longer, resulting in deep acid penetration and severe burns. The fluoride ion readily penetrates the skin causing destruction of deep tissue layers and bone. Systemic fluoride poisoning has been associated with sudden death due to cardiac arrest, which can occur with burns to as little as 2.5% of body surface area. Inhalation of HF vapor may cause ulcers of the upper respiratory tract and can also lead to systemic fluoride ion poisoning.

HF should be used in an operational chemical fume hood. In addition to a chemical fume hood, customary PPE including an apron or lab coat, close-toed shoes, goggles, and nitrile gloves, a full face shield and heavy neoprene over-gloves are required. HF is usually stored in polypropylene containers since it attacks glass and other silicon containing compounds. NOTE: HF reacts with silica to produce silicon tetrafluoride, a poisonous, corrosive gas known to cause pneumonitis and pulmonary edema. Older polypropylene containers can become brittle or start to bubble. If such a container is found, contact EHS & RISK MANAGEMENT immediately. If concentrated HF contacts the skin call 911 immediately and inform medical personnel that a hydrofluoric acid exposure has occurred; also, inform EHS & RISK MANAGEMENT of the exposure incident.

Labs using hydrofluoric acid must have a supply of either calcium gluconate gel (preferred), or a 10% W/V calcium gluconate solution on hand as an antidote. Topical applications of the gel or solution should be applied frequently and liberally while the victim is awaiting further medical attention. Call **EHS & RISK MANAGEMENT** for more information.



Nanomaterials

Anyone who uses nanomaterials in research may potentially be exposed to resultant nanoparticles through inhalation, dermal contact, or ingestion, depending upon how nanomaterials are used and handled. Although the potential health effects of such an exposure are not fully understood, scientific studies indicate that at least some of these particles are biologically active, may readily penetrate intact skin, and have produced toxicologic reactions in the lungs of exposed animals.

It is important to note that the properties of engineered nanomaterials differ substantially from those of the same material in bulk or macro-scale form. Properties that may be important in understanding the toxic effects of nanomaterials include: particle size and size distribution, agglomeration state, shape, crystal structure, chemical composition, surface area, surface chemistry, surface charge, and porosity.

Research involving the use and/or development of nanomaterials may carry with it the following potential health risks:

- Toxicity of nanoparticles is likely greater than that of the same mass of larger particles.
- Granulomatous pneumonia, fibrosis and other nonmalignant respiratory diseases could result from exposure to nanoparticles.
- Exposure to metal and metal oxide nanoparticles could result in DNA damage.
- Certain nanoparticles may be human carcinogens.

Prior to working with nanomaterials, implement appropriate control measures, and develop SOP(s). Laboratory best practices must also be observed to effectively minimize or eliminate exposure to nanoparticles. Notify EHS & RISK MANAGEMENT if you plan to use nanomaterials.



Appendix A: Research/ Laboratory SOP Template

Laboratory Information

Department	Click here to enter text.
Principle Investigator(s)	Click here to enter PI name(s); can list more than one for multidisciplinary projects
Location(s) covered by this SOP	Click here to enter building(s), room(s)
Creation date	Click here to enter a date.
SOP Author	Click here to enter text.
Revision date	Click here to enter a date.

Type of SOP

- Specific laboratory procedure or experiment
(Examples: synthesis of chemiluminescent esters, folate functionalization of polymeric micelles)
- Generic laboratory procedure
(Examples: distillation, RNA extraction)
- Generic use of specific chemical or class of chemicals with similar hazards
(Examples: Ethidium bromide, mineral acids)

Brief Description of Procedure or Experiment

Click here to enter text. Describe the purpose of the procedure or experiment. Do not include step-by-step instructions here.

General Hazard Identification - Equipment/ Mechanical / Electrical Hazard

Click here to enter text. Describe all equipment that poses a hazard such as power tools, cutting instruments, needles, scalpel blades, etc.

General Hazard Mitigation

Click here to enter text. Describe what engineering controls and PPE are required to minimize exposure to the above hazards.

Hazard Assessment – Biological, Chemical, Radiation

- Biological Hazard Not applicable
- Micro-organisms BSL1 BSL2
- Body Fluids/ Tissues Animal Human



Complete a copy of Appendix B - Biological Material Hazards Assessment form, for each hazard class checked above.

Radiation Hazard D Notapplicable

Non-ionizing (microwave, infrared, laser, ultraviolet)

Eye Protection: Click here to enter text. Specify what type of eye protection is required for the above checked hazard.

Ionizing - Type: Alpha emitter Beta emitter Gamma emitter X-ray

If any of the ionizing radiation boxes are checked, contact the Radiation Safety Officer for assistance – 409-880-8276, or nmacy@lamar.edu.

Chemical Hazard

List all chemicals and reagents used in this SOP. Copy and insert more rows as needed.

Table with 3 columns: Chemical/ Reagent name, CAS# (if none, enter 'see SDS'), GHS Non-hazardous? Y or N

For each hazardous chemical (GHS non- hazardous listed as N or No) listed above, provide the following information (copy and paste as needed).

Storage Requirements: Click here to enter text. Specify what type of storage is required, including any information about incompatible chemicals and conditions.

Handling Requirements: Click here to enter text. Specify what type of handling is required, including any requirements for engineering controls (fume hood, ventilation), and what types of PPE (what kind of gloves, what sort of eye protection, etc.) are required.

Decontamination Procedures: Click here to enter text. If the chemical is acutely hazardous, carcinogenic, or reproductively hazardous, indicate how decontamination of glassware, workspaces, equipment, or clothing should be conducted.

Step-by-Step Operating Procedure Hazard Assessment

Find one more person who is involved in this field of research, and one outside, competent perspective. Together, follow the method below.

- 1.) Lay out a list of every step in the planned procedure.
2.) For each step, identify the potential hazards, even those that seem fully controlled, in the second column of the Procedure Table below.



- 3.) Record each hazard individually in the first column of the Hazard Table. For each hazard, determine the appropriate control measures, including any PPE, engineering controls, or designated work area.

Guidance on Engineering and Ventilation Controls – Review SDS, safety literature and peer-reviewed journal articles to determine appropriate engineering and ventilation controls for your process or experiment.

Guidance on Personal Protective Equipment – Consult SDS to determine what sorts of PPE may be required. Such PPE may include gloves, aprons, lab coats, safety glasses, goggles, face shields, and respirators. For more information, consult sections 8.3 and 8.4 of the Chemical Hygiene Plan.

Designated work area(s) – Required whenever carcinogens, highly acutely toxic materials or reproductive toxins are used. The intent of a designated work area is to limit and minimize possible sources of exposure to these materials. The entire laboratory, a portion of the laboratory or a laboratory fume hood or bench may be considered a designated work area. This area MUST be wiped down following EACH use to minimize possible exposure.

- 4.) Determine the severity of the hazard, if it did occur, and assign it a Severity Rating value, based on the table below. Enter the hazard’s Severity Rating in the Hazard Table’s S column.

	Severity Ratings
1	Possible death
2	Could cause severe injury
3	Lost workdays at most
4	Superficial damage

- 5.) Determine the probability of the hazard occurring, given the control measures in place. Assign it a Probability Rating letter, based on the table below. Enter the hazard’s Probability Rating in the Hazard Table’s P column.

	Probability
A	Likely to occur somewhat regularly
B	Probably will happen at least once
C	Might occur a few times
D	There's a reasonable chance
E	Basically theoretical; fully controlled

- 6.) Combine the Severity Rating and Probability Rating to assign the hazard an overall Hazard Priority. Enter this value in the Hazard Table’s Hazard Priority column.

- 7.) Use the Hazard Priority Ranking Matrix to determine the hazard’s Risk (Unacceptable, High, Medium, or Low).



Hazard Priority Ranking Matrix				
Probability	Severity			
	1 Catastrophic	2 Critical	3 Marginal	4 Negligible
A - Very Likely	1A	2A	3A	4A
B - Probably	1B	2B	3B	4B
C - Occasionally	1C	2C	3C	4C
D - Remote	1D	2D	3D	4D
E - Improbable	1E	2E	3E	4E
	Unacceptable	High	Medium	Low

8.) Determine the approval required, based on the hazard’s Risk and the table below.

Risk	Approval Required
Low	P.I.
Medium	Department Head
High	College Dean
Unacceptable	You May Not Proceed; No Approval Sufficient

9.) Acquire approval for the overall procedure from the highest official required for the procedure, and each rung below said highest official. Any approval above the P.I. must be in writing.

Procedure Table

Procedure - Step-by-Step Description	Potential Hazards if Step is Not Done or Done Incorrectly (if any)
Don personal protective equipment	Risk of exposure to any hazards present
Check the location/ accessibility/ certification of safety equipment that serves your lab. Notify the PI/ RLS of any deficiencies.	Equipment may malfunction and not provide expected protection, posing a risk of exposure
Describe the next step in the procedure	Describe what could happen if an unexpected event occurred.
Describe the next step in the procedure. Insert additional rows in table, as needed.	Describe what could happen if an unexpected event occurred.
Dispose of hazardous solvents, solutions, mixtures, and reaction residues as hazardous waste. See Waste Disposal section for more information.	Describe what could happen if an unexpected event occurred.



<p>Clean up work area and lab equipment. Describe specific cleanup procedures that must be performed after completion of your process or experiment. For carcinogens and reproductive toxins, designated areas must be immediately wiped down following each use.</p>	<p>Describe what could happen if an unexpected event occurred.</p>
<p>Remove PPE and wash hands.</p>	<p>Cross-contamination of biological and chemical materials to surfaces outside of the lab</p>

Hazard Table

Potential Hazard	Control Measures	S	P	Hazard Priority	Risk	Approval

Emergency Procedures

Health-Threatening Emergencies

Fire, explosion, health-threatening hazardous material spill or release, compressed gas leak, valve failure, etc.

- **CALL 911**
- Alert people in the immediate vicinity
- Pull Fire Alarm
- Evacuate building and go to your Emergency Assembly Area: **Click here to enter text. Indicate EAA location(s) for the building(s) listed for this SOP**
- Remain nearby to advise emergency responders
- Once personal safety is established, call EHS
- Provide local notifications (see Emergency Phone Numbers)



Note: For compressed gas leaks, shut off gas supply ONLY if this can be done safely, without risk to personnel.

Injuries and Exposures

- Remove the injured/ exposed individual from the area, unless it is unsafe to do so because of the medical condition of the victim or the potential hazard to rescuers.
- **Call 911** if immediate medical attention is needed.
- Call EHS to report the exposure (see Emergency Phone Numbers)
- Administer first aid as appropriate.
- Flush contamination from eyes/ skin using the nearest emergency eyewash/shower for a minimum of 15 minutes. Remove any contaminated clothing. Fire blankets and sweat suits are available in every laboratory for use as needed.
- Bring to the hospital copies of SDSs for all chemicals the victim was exposed to.

Non-Health-Threatening Emergencies

Injuries and Exposures

- Flush contamination from eyes/skin for a minimum of 15 minutes.
- Administer appropriate first aid.
- Go to EHS website to report the incident on Origami.

Small/ manageable spills

In the event of a minor spill or release that can be safely cleaned up using laboratory PPE and spill kit, spills or releases which have been contained within the laboratory (via secondary containment, in a fume hood, on a bench or the floor), spills of less than 500 mL of any flammable material, or spills of materials that do not require respiratory protection for cleanup:

Notify personnel in the area and keep people away from the area. Eliminate all sources of ignition.

Protect yourself:

- Review the SDS for the spilled material or use your knowledge of the hazards of the material to determine the appropriate level of protection.
- Wearing appropriate PPE, clean up the spill with absorbent powder or pads. Collect spill cleanup materials in a tightly closed container or double plastic bags. Manage spill cleanup debris as hazardous waste. Contact EHS for waste pickup.
- Dispose of broken glass in a new broken glass container – DO NOT put other materials in the broken glass container.

DO NOT clean up spills requiring respiratory protection – CALL EHS & RISK MANAGEMENT.

Large/ unmanageable spills

For highly reactive, highly acute toxin, spills or releases which have impacted the environment (via sink / sewer system, soil or air outside the building), spills larger than 500mL of any flammable material, or spill of any material requiring respiratory protection for cleanup:

Protect yourself and others:

- Contact PI/ RLS and EHS & Risk Management personnel on Emergency Phone Numberlist.
- Alert people in the vicinity of the spill, advise them to evacuate the immediate area.
- Restrict access to the area of the spill. Eliminate all sources of ignition on your way out.



- Evacuate to a safe area. Remain nearby to advise PI and EHS.

Lab-Specific (Biological/Chemical/Radiation Hazard specific) Procedures

This section is for any emergency procedures different from standard responses, or for additional emergency information due to the nature of materials or task. Include **information on gas leaks, chemical spills, and personal exposure / medical emergency as appropriate (e.g. Calgonate gel for hydrofluoric acid exposure).**

Decontamination/ Waste Disposal and Pollution Prevention

Decontaminate disposable items (e.g. pipet tips, plates) and empty chemical containers by triple rinsing with a liquid that will dissolve the material.

All three rinses must go into an appropriate waste container. If a non-aqueous solvent is used, the rinsed container must be placed in a fume hood to allow remaining vapors to be drawn up the hood.

Decontaminated items can go in non-hazardous trash.

Identify amounts of waste anticipated and appropriate disposal procedures. Segregate waste by hazard class (flammable, corrosive, etc.), state (liquid, solid) and, for organic solvents, halogenated and non-halogenated. Store waste appropriately for the hazard class. Contact the EHS Building & Lab Safety Coordinator if you need assistance.

General hazardous waste disposal guidelines

Label Waste

Affix hazardous waste label (available from EHSRM) on all waste containers as soon as the first drop of waste is added to the container. Keep waste label updated regarding contents and hazards.

DO NOT share waste containers with other research groups. Each research group shall maintain their own waste containers for their procedures.

Store Waste

Store hazardous waste in closed containers, in secondary containment, and in your laboratory's designated location. Waste containers MUST be closed at all times, except when waste is being added to the container.

Waste containers are considered FULL when they contain approximately 75% of the maximum volume. DO NOT OVERFILL – this is an exposure hazard for all persons handling and disposing of the waste.

Dispose of Waste

E-mail EHS & Risk Management's Building and Lab Safety Coordinator, and Hazardous Waste Disposal Assistant, to have full, appropriately labeled waste containers picked up for disposal by EHSRM. Provide copies of the materials' SDS.

Methods of Disposal D Consumed during process

D Neutralized as part of procedure

D Sink disposal (GHS non-hazardous liquids only – MUST HAVE EHS approval)

D Hazardous waste by EHS (will be lab-packed by a Hazardous Waste Management company if cannot go to a sanitary landfill; associated disposal costs may be assessed to your research or department budget)



Chemical specific instructions:

Click here to enter text. Describe the measures to take, procedures to follow for proper disposal or packaging of chemical waste.

Training Requirements

Prior to conducting any work in this SOP, the PI or designee must provide training to his/her laboratory personnel specific to the hazards involved in working with this substance, work area decontamination and emergency procedures.

The PI must provide or make readily available a copy of this SOP and copies of SDSs provided by the manufacturer.

The PI must ensure that his/her laboratory personnel have attended appropriate and required laboratory safety training or refresher training within the last 12 months.

Lab-Specific Training

Click here to enter text. List any additional training required before laboratory personnel can begin work using this SOP.

Location of SDS(s)

PIs are responsible for maintaining a readily accessible database of Safety Data Sheets for the materials that they are using, are producing, or have a reasonable expectation of producing (e.g. side products of reactions). This database may be physical (e.g. an SDS book, kept near the work site) or digital (e.g. a database, easily accessible from work site computers).

Click here to enter text. Indicate the location in the lab where relevant SDSs can be found.



Approvals

In accordance with EHS & Risk Management, I accept the responsibility for the proper use and disposal of these materials in the laboratory work described above and have assigned chemical safety responsibilities within the laboratory to people with appropriate training and/or experience.

[Click here to enter a date.](#)

PI Signature

I have reviewed and approve this Standard Operating Procedure.

[Click here to enter a date.](#)

PI Signature

[Click here to enter a date.](#)

Department Head Signature (if applicable)

[Click here to enter a date.](#)

College Dean Signature (if applicable)

[Click here to enter a date.](#)

EHS & Risk Management

Emergency Contacts

Principle Investigator	Click here to enter text.	Click here to enter text.
EHS Building & Lab Safety	Nathan Macy	409-880-8276; 630-672-5899
Manager of Campus	Miriam Morgan	409-880-7249
Radiation Safety Officer	Nathan Macy	409-880-8276; 630-672-5899
Building Coordinator	Click here to enter text.	Click here to enter text.
ALL EMERGENCIES	911 systems – LUPD	911; 409-880-7777
LUPD – Non-emergency	Dispatch	409-880-8307



Documentation of Training and Proficiency

Add additional lines to the table as necessary.

The PI's initials indicate the below listed persons have been trained and are proficient in this SOP.

I have read and understand the content of this SOP.

Name - Print	Signature	Date	PI's Initials

Appendix B – Biological Material Hazard Assessment

Complete and attach a Biological Material Assessment form to the SOP. One form may be used for all materials/agents with the same potential hazards and protective measures.

Biological Agent(s): [Click here to enter text.](#)
(Organisms, Tissues, Fluids, etc.)

Hazard Identification

Identify the hazard of the agent(s) listed

above: Micro-organisms BSL1 BSL2

Body fluids or tissues Animal Human

Modes of Exposure/Transmission – check all that apply

Inhalation Ingestion Mucous membranes Percutaneous (cut, needle stick, etc.) Skin contact

Bloodborne Pathogen

The Bloodborne Pathogens Standard (29 CFR, Bloodborne Pathogens. - 1910.1030) applies to all occupational exposure to blood or other potentially infectious materials. Blood means human blood, human blood components, and products made from human blood. Bloodborne Pathogens means pathogenic microorganisms that are present in human blood and can cause disease in humans. These pathogens include, but are not limited to, hepatitis B virus (HBV), hepatitis C virus (HCV) and human immunodeficiency virus (HIV). Additionally, “Other Potentially Infectious Materials” (OPIM) are included under this standard. OPIM means (1) The following human body fluids: semen, vaginal secretions, cerebrospinal fluid, synovial fluid, pleural fluid, pericardial fluid, peritoneal fluid, amniotic fluid, saliva in dental procedures, any body fluid that is visibly contaminated with blood, and all body fluids in situations where it is difficult or impossible to differentiate between body fluids; (2) Any unfixed tissue or organ, including cells and cell lines, (other than intact skin) from a human (living or dead); and (3) HIV- containing cell or tissue cultures, organ cultures, and HIV- or HBV- containing culture medium or other solutions; and blood, organs, or other tissues from experimental animals infected with HIV, HBV or HCV. The above additionally applies to non-human primate materials.

To help determine if a worker is at risk for contact with BBP, please check all that apply.

Will any lab personnel:

- Work with human blood, blood products or body fluids?
- Work with unfixed human cells (including tissue culture cells and cell lines), human tissues or organs?
- Work with non-human primates (NHP) or NHP blood, blood products or body fluids?
- Work with unfixed NHP cells (including tissue culture cells and cell lines), NHP tissues or organs?
- Work with bloodborne pathogens (e.g. HIV, Hepatitis B, Hepatitis C or other infectious agents able to be spread via blood)?
- Work with animals or animal tissues that have been infected with a BBP?



Perform tasks which may potentially result in exposure to human or animal blood, body fluids, organs, or tissues which are infected with the hepatitis B virus or other bloodborne pathogens?

Handle sharp instruments such as knives, needles, scalpels, or scissors which have been used by others working with human blood or other potentially infectious materials to include human organs, tissue or body fluids OR used by others working with similar body parts and fluids from animals infected with the hepatitis B virus or other bloodborne pathogens?

If ANY of the above questions are checked, then the worker is considered to be at occupational risk of contracting Hepatitis B or other bloodborne pathogens. All workers at risk MUST take the Bloodborne Pathogen Training. Contact EHS & Risk Management for training.

The worker must be given the opportunity to receive a no-cost HBV vaccination. If they decline this offer, then they must sign and date the following affidavit:

“I understand that due to my occupational exposure to blood or other potentially infectious materials I may be at risk of acquiring hepatitis B virus (HBV) infection. I have been given the opportunity to be vaccinated with hepatitis B vaccine, at no charge to myself. However, I decline hepatitis B vaccination at this time. I understand that by declining this vaccine, I continue to be at risk of acquiring hepatitis B, a serious disease. If in the future I continue to have occupational exposure to blood or other potentially infectious materials and I want to be vaccinated with hepatitis B vaccine, I can receive the vaccination series at no charge to me.”

Medical Considerations

Describe what medical screening and surveillance is necessary, including any recommended vaccinations. If an individual declines recommended HBV vaccine, the Vaccination Declination form must be signed.

[Click here to enter text.](#)

Safety Controls and Equipment

Engineering Controls – check all that apply

Biosafety cabinet

Other: [Click here to enter text. Specify other engineering controls required.](#)

Personal Protective Equipment (PPE) – check all that apply

All recommended PPE is based on the most severe/ extreme conditions of exposure. PPE may be scaled back based on actual working quantities and/ or conditions.

MANDATORY - Appropriate clothing. See Chemical Hygiene Plan for more information.

Eye Protection – Safety glasses/ goggles must have ANSI stamp and fit properly; goggles should be snug enough to prevent any splash from reaching the eyes.

Safety glasses

Splash-proof goggles



Face shield (only in addition to glasses or goggles, NEVER as the sole source of eye protection)

Body protection – An appropriately-sized lab coat must be worn and fastened. Laboratory coat sleeves must be of sufficient length to prevent direct skin exposure while wearing gloves.

Lab Coat Apron

Click here to enter text. Specify any special instructions for decontamination and/or care of reusable body protection.

Disposable Lab Coat

Click here to enter text. Specify any special instructions for use and disposal of disposable body protection

Hand protection – Wear chemical-resistant gloves. REMOVE DISPOSABLE GLOVES EVERY TIME THEY BECOME CONTAMINATED OR YOU LEAVE THE LAB. WASH YOUR HANDS EVERY TIME YOU REMOVE YOUR GLOVES.

Gloves Single glove Double glove

Thickness Click here to enter text. Length Standard Long Material

Butyl Latex Neoprene Nitrile

Thermal protection for: Heat Cold

Other Click here to enter text. Specify SDS recommended glove material.

Respiratory protection is generally not required for laboratory research, provided the appropriate engineering controls are employed. For additional guidance on respiratory protection, contact EHS.

Cleaning and Disinfection

List and describe laboratory decontaminants and disinfectants that are used. List all applications and the decontaminating or disinfecting procedures with regards to the instrument or surface, agent used, frequency of agent preparation, allowed contact time before wiping and frequency of decontamination/disinfection.

Click here to enter text.

Waste Generation and Disposal

Identify the types of waste generated and procedures for handling biological waste including contaminated and non-contaminated waste and use of sharps.

Click here to enter text.

Accident/ Exposure Response

Are there first aid or emergency response procedures necessary for this material beyond rinsing with water?

No

Yes, specify in the Emergency Procedures section of the SOP.



Appendix C: Hazardous Materials Shipping/Receiving Guide

C-1 Shipping Hazardous Materials

Since 1990, the U.S. Department of Transportation (DOT) has regulated the transport of "hazardous materials" in all modes of transportation (air, ground and sea). Transportation of "dangerous goods" by air has been regulated by the International Air Transport Association (IATA) since 1956. The DOT and IATA regulations are intended to ensure that all who come in contact with a shipment of hazardous materials are properly informed of the hazards presented by the materials, and the measures necessary for their safe transport.

C-2 What are Hazardous Materials and Dangerous Goods?

Hazardous materials are substances or materials, which have been determined by the Secretary of Transportation to be capable of posing an unreasonable risk to health, safety, and property when transported in commerce. The term includes hazardous substances, hazardous wastes, marine pollutants, elevated temperature materials, materials designated as hazardous in the Hazardous Materials Table ([HMT](#)), and materials that meet the defining criteria for [hazard classes](#) and divisions in [49 CFR 173](#).

Dangerous goods are articles or substances which are capable of posing a significant risk to health, safety or property when transported by air. The transportation of these articles and substances is regulated under the IATA Dangerous Goods Regulations. DOT and IATA regulations are similar, but are not always the same. For example, dry ice shipped via ground transportation is not regulated as a hazardous material; however, when shipped by air, dry ice is considered a dangerous good.

Hazardous materials and dangerous goods include items such as laboratory chemicals, radioactive materials, compressed gases, biological agents, dry ice (when shipped by air) and equipment or instruments that contain hazardous materials or dangerous goods. To comply with DOT and IATA regulations, these materials must be properly classified, packaged, labeled, documented and handled.

C-3 Lamar University Procedures for Offering Hazardous Materials for Shipment

Following these procedures will help to ensure that your package will arrive at its destination on time and intact. More importantly, it will ensure that everyone involved in the transport of the material will know what it is and how to safely deliver it. The following procedures apply to all hazardous material/dangerous goods packages except radioactive materials. For assistance shipping radioactive materials call the Radiation Safety Officer (409-880-7917).

1. Sender brings hazardous materials to EHS & Risk Management along with the Safety Data Sheet (SDS).
2. EHS & Risk Management will package, label and complete the proper shipping papers for the

material.

3. EHS & Risk Management will arrange for the shipping by a commercial carrier.
4. EHS & Risk Management will be reimbursed by sender for all shipping costs, including packaging, labels, and shipping.

Note: Certain LU employees may be authorized by EHS & Risk Management to ship hazardous materials and/or dangerous goods provided they have successfully completed the training requirements specified in [DOT](#) and [IATA](#) regulations.

For Shipping Assistance, Contact:

EHS & Risk Management: 409-880-7249

Commercial Carrier of Hazardous Materials, Contact:

FedEx: 1-800-GoFedEx, or 1-800-463-3339

C-4 Receiving Hazardous Materials

Hazardous materials received at Lamar University via domestic carrier are regulated during transport by the U.S. Department of Transportation (DOT). These materials have specific packaging and labeling requirements. All packages containing hazardous materials display a diamond shaped DOT label(s) that fall into one or more of 9 categories or hazard classes ([refer to the DOT labels](#))

If your area receives any package displaying these types of labels, the following procedures should be followed:

- Packages displaying an "Explosive" label ([Hazard Class 1](#)) - call EHS & Risk Management.
- Packages displaying a "Radioactive" label ([Hazard Class 7](#)) - Should not be accepted. These types of packages should go directly to Shipping & Receiving, 1050 E Lavaca; Beaumont, TX 77705.
- If packages displaying a "Radioactive" label (Hazard Class 7) are accidentally accepted, call the Radiation Safety Officer (RSO) (409-880-8276).
- All packages received displaying labels with [Hazard Classes 2-6 and 8-9](#) can be campus delivered as any other package unless they are damaged or leaking.
- Hazardous material packages should be campus delivered immediately or within three hours after receiving for refrigerated material or within 24 hours for all other packages. If this is not possible, contact the package recipient.
- While hazardous material packages are awaiting campus delivery, segregate them according to Appendix J, which describes how to safely store chemicals.
- If packages are damaged or leaking at the time of delivery, do not accept from carrier, and call EHS & Risk Management.
- If package becomes damaged or leaks after the carrier has delivered it, call EHS & Risk Management. Do not handle, cordon off the area, and notify other personnel working in the area.



C-5 Training Requirements

Anyone who...

- Loads, unloads or handles hazardous material/dangerous goods packages;
- Determines acceptable shipping containers;
- Determines whether a material to be shipped is a hazardous material or dangerous good;
- Packages hazardous materials/dangerous goods for shipment;
- Labels hazardous materials/dangerous goods packages;
- Fills out shipping papers; and/or
- Transports hazardous materials

...must be trained according to the training requirements specified in the DOT and IATA regulations ([49 CFR 172.700](#) and [DGR 1.5](#) respectively). For assistance in receiving training contact EHS & Risk Management, 409-880-8276.

C-6 Additional Information: US Postal Service Suspicious Package Guidelines

The following link refers to information about suspicious packages that may arrive through the mail or other parcel delivery services: [Suspicious Mail Poster](#)

C-7 Laboratories Shipping Hazardous Chemicals

Laboratories that ship hazardous chemicals (other than certain small quantities for analysis) are considered chemical manufacturers or distributors under the Hazard Communication Standard, and must ensure that any hazardous chemicals leaving the laboratory have manufacturer's labels that include the minimum content specified in the "Labeling" section of the Hazard Communication Program. Also, the name and address of the University department responsible for the hazardous chemical(s) is required. Additionally, laboratories shipping hazardous chemicals must provide a GHS-compliant Safety Data Sheet (mandatory starting December 1, 2015) to distributors or other employers who will receive the hazardous chemicals. Contact EHS & Risk Management for shipping information and for MSDS/SDS requirements.



Hazardous Materials Warning Labels

Actual label size: at least 100 mm (3.9 inches) on all sides

CLASS 1 Explosives:
Divisions 1.1, 1.2, 1.3, 1.4, 1.5, 1.6



§172.411

* Include compatibility group letter.

** Include division number and compatibility group letter.

CLASS 2 Gases:
Divisions 2.1, 2.2, 2.3



§172.405(b), §172.415, §172.416, §172.417

CLASS 3 Flammable Liquid



§172.419

CLASS 4 Flammable-Solid, Spontaneously Combustible, and Dangerous When Wet:
Divisions 4.1, 4.2, 4.3



§172.420, §172.422, §172.423

CLASS 5 Oxidizer, Organic Peroxide: Divisions 5.1 and 5.2



Organic Peroxide, Transition-2011

§172.426, §172.427

CLASS 6 Poison (Toxic), Poison Inhalation Hazard, Infectious Substance: Divisions 6.1 and 6.2



§172.323, §172.405(a), §172.429, §172.430, §172.432

For Registered Medical Waste (RMW), an Infectious Substance label is not required on the outer packaging if the OSHA Biohazard marking is used as prescribed in 29 CFR 1910.1050(g). CDC Etiologic Agent label must be used as prescribed in 42 CFR 72.3 and 72.6. A bulk package of RMW must display a BIOHAZARD marking.

CLASS 8 Corrosive



§172.442

CLASS 9 Miscellaneous Hazardous Material



§172.441

Cargo Aircraft Only



Mandatory January 1, 2013



Empty Label



§172.448

§172.450



Appendix D: Hazardous Material Emergencies and Spills

The following guidelines and procedures are to be used in case of chemical emergencies or spills. For more detailed information on any of these subjects, contact EHS & Risk Management.

D-1 Chemical Exposures

The following are general first aid ideas for unknown chemical exposures. The best information for treatment of exposure to a particular chemical is found on the chemical's Safety Data Sheet (SDS).

Inhalation: Remove to fresh air. If not breathing, give artificial respiration. Seek medical attention immediately.

Eye Contact: If a chemical has been splashed into the eyes, immediately wash the eye and inner surface of the eyelids with copious amounts of water for 15 minutes, lifting upper and lower eyelids occasionally. Check for and remove any contact lenses at once. Seek medical attention immediately.

Ingestion: Consult SDS, and/or call the Poison Control Information Center at 800-222-1222. Follow directions and seek attention immediately.

Minor Skin Contact: Promptly flush the affected area with water and remove any contaminated clothing. If symptoms persist after washing, seek medical attention.

Major Skin Contact: If chemicals have been spilled over a large area of the body, quickly remove all contaminated clothing while using the safety shower. Repeat if pain returns. Wash off chemicals by using a mild detergent or soap and water. Do not neutralize chemicals or apply salves or bandages. Leave affected area clean and open to the air. Seek medical attention immediately.

Remember that for some chemicals, such as hydrofluoric acid, effects resulting from exposure may not become apparent until hours or days later. Consult the SDS for any chemical to which someone has been exposed, even if no immediate injury is apparent.

If clothing is on fire, help the individual to the floor and roll that person around to smother the flames. If a safety shower is immediately available, douse the person with water; running to a remote shower will only fan the flame.

Report instances of chemical exposure to EHS & Risk Management after medical attention has been received.

D-2 Accident Reporting & Workers Compensation Procedures

All accidents, injuries, incidents, or near-misses must be reported to the supervisor or other person in charge. Accidents and injuries resulting in the need for first aid, medical attention, or lost work-time must be documented. Persons responsible for the affected individual(s) must complete the appropriate reports:

- [Student Injuries](#) (Student Health Center)
- [Employee Injuries](#) (Workers' Compensation)



D-3 Emergencies

All laboratory personnel must know what to do in case of an emergency. Laboratory work must not be undertaken without knowledge of the following procedures:

- How to report a fire, injury, chemical spill, or other emergency.
- The location of emergency equipment, such as safety showers and eyewash fountains.
- The location of fire extinguishers and spill control equipment.
- The locations of all available exits for evacuation from the laboratory.
- The location of emergency evacuation meeting areas.

The Principal Investigator must ensure all laboratory personnel are familiar with the above procedures.

Laboratory personnel should be aware of their level of expertise with respect to the use of fire extinguishers and emergency equipment, response to chemical spills, and ability to treat injuries. They should not take actions outside the limits of their expertise, but should call on trained personnel for assistance.

Post emergency telephone numbers and the telephone numbers of individuals responsible for the laboratory by the laboratory telephone and on signage affixed to the entrance.

Emergency Procedures

- Call 911 immediately for all fires and any accidents or spills with injuries that require urgent medical attention.
- Call EHS & Risk Management, (409) 880-7249 during normal business hours for accidents or spills without injuries or with injuries that do not require urgent medical attention. After normal hours and on weekends and holidays, call LUPD at (409) 880-7777.



Type of Emergency	Who to Call
All Fires Accidents or Spills with injuries that require urgent medical attention	At Any Time Campus Police or Local Emergency Responders 911
Accidents or spills without injuries or with injuries that do not require urgent medical attention (i.e. on-site first aid only)	During Normal Business Hours Environmental Health and Safety (409) 880-7249 Outside Normal Business Hours, Weekends, Holidays Campus Police (409) 880-7777
Emergencies involving radiation or radioactive materials	During Normal Business Hours Radiation Safety Officer 409-880-8276 Outside Normal Business Hours, Weekends, Holidays Campus Police (409) 880-7777

D-4 Management of Spills

Hazardous chemical, biological, or radiological spills can be handled effectively when a plan of action has been developed. To respond to any type of spill, lab personnel must be adequately trained. Contact EHS & Risk Management for training assistance. Spill awareness and/or procedures include the following:

- The potential location of spills.
- The quantities of material that might be released.
- Chemical, physical and hazardous properties of the material. This information may be obtained from the Safety Data Sheet or label.
- The types of personal protection equipment needed for cleanup.
- Location and contents of spill kits that should be made available where possible.

The following table presents a list of suggested materials for spill control kits. **Note: Not all materials on this**



list are required to complete a spill control kit, only those that apply to a particular laboratory.

COMPONENTS	QTY ¹	PURPOSE
Plastic Tote	1 each	hold kit contents below
Clay Absorbent (i.e. Oil-Dry, Kitty Litter)	5 lbs.	absorbent for organic solvents, oil spills
Sodium Bicarbonate	5 lbs.	neutralizes acid (base) spills
Magic Sorb®	5 lbs.	all purpose (except Hydrofluoric Acid)
Sodium Hypochlorite (bleach)	1 gal.	disinfectant for biohazardous spills
Absorbent pads/ paper	6 units	absorb radioactive/biohazardous spills
Sulfur	1 lb.	reactant for mercury spills
Mercury "sniffer" bottle	1 each	pick-up mercury droplets
Silver Shield, Nitrile or neoprene coated gloves	2 pairs	PPE
Disposable gloves	1 box	PPE
Safety Goggles	2 pairs	PPE
Whisk broom or bench brush	2 each	collect spill waste
Dustpan (non-sparking)	2 each	collect spill waste
Polyethylene bags	6 each	collect and dispose waste
Impermeable red biomedical waste bags	6 units	dispose biomedical waste
Tongs or forceps	1 each	picking up sharps/syringes
Duct tape	1 roll	seal spill waste in bag
Other (as needed)		

¹These quantities are suggested amounts per laboratory. Items may be added to or deleted from the spill kit depending on the variety and quantity of chemicals used in a laboratory. Additional items can include absorbent towels, spill pillows, mops, Radiacwash, etc.



A simple chemical release is generally small in quantity, gradual in dispersion, and easy to contain. Simple releases may be managed with a laboratory spill control kit. The Principal Investigator or the laboratory supervisor must be informed when this type of release occurs. The following are some routine procedures to use with a simple chemical spill:

- Neutralize acids whenever possible. Use baking soda (sodium bicarbonate) or some other appropriate neutralizer. (Never neutralize a spill on skin, use water.)
- Control and absorb liquid releases. Use absorbent materials (Speed Dri, oil dry, spill socks, pads, etc.) to dike the contaminated areas and prevent the spread of a liquid release.
- Store waste absorbent materials properly. After cleaning the releases area, place waste products in a properly labeled container and contact EHS & Risk Management for disposal.
- Decontaminate the area and affected equipment. Increase ventilation to the area using fans or opening windows if available. Contact Facilities Management for an indoor air quality assessment if necessary.

When dealing with a simple release, make sure to label properly all disposal bags with the names of the spilled chemicals and the approximate amounts. Also include on the label “contains broken glass,” when appropriate. Always restock the spill control kit after use.

Complex Chemical Releases

Complex chemical releases require outside assistance from properly trained individuals. These involve the release of large amounts of chemicals or chemicals of high toxicity. Evacuate the area. Contact LUPD and EHS & Risk Management. Have all involved personnel wait in a predetermined evacuation area.

Guidelines for Mercury Handling, Storage, and Spill Cleanup

This guideline, specifically written for mercury, was developed because of the toxicity of the element. Mercury is a chronic toxin and particularly insidious due to its long latency period. It, like benzene or lead, is a cumulative poison that produces body damage through exposure to small concentrations over a long period of time.

Elemental mercury can be absorbed through the skin, inhaled as a gas, or ingested. Although it is a liquid at room temperature, it is constantly emitting vapors that are colorless, odorless, and tasteless. Mercury poisoning causes emotional disturbances, unsteadiness, inflammation of the mouth and gums, fatigue, memory loss, and possibly kidney damage.

Handling – All work with mercury should be performed in a properly functioning fume hood. At a minimum, a lab coat and at least one pair of disposable gloves should be worn. Secondary containment should be utilized when transporting or working with mercury.

Storage – Containers of mercury should be kept closed and stored in secondary containers in a well-ventilated room. The secondary container, for storage or use, should be enameled or plastic for easy cleaning. It should also be large enough to hold the volume of mercury in use.

Spills – Notify everyone in the area that a spill occurred. Call EHS & Risk Management.

- Isolate the area to prevent spreading.



- A mercury spill kit must be used, and proper procedures followed.
- At a minimum, wear gloves, lab coat, and shoe covers.
- Place mercury and mercury device in a bottle or zip-locked bag and label.
- Wash thoroughly after the cleanup is completed.
- Place bags in the Designated Waste Area and call EHS & Risk Management for a pick up and a survey.
- For large spills (barometers, manometers) call EHS & Risk Management for cleanup.

Accidental Release of Biohazardous Agents

Laboratories in which biohazardous agents are used must have the ability to contain and control accidental releases of these agents. The laboratory spill kit must incorporate the appropriate items to accomplish containment including, but not limited to, the following:

- Appropriate disinfectant/decontaminant
- Proper PPE (gloves, goggles, etc.)
- Red biomedical waste disposal bags

Laboratory procedures and biohazardous agents present in a specific laboratory will determine what additional items may be necessary.

Spills of Radioactive Substances

The accidental release of radioactive substances falls into two primary categories:

- Minor incident – Incidents involving the release or spillage of less than 10 uCi of a radionuclide in a non-volatile form.
- Major incidents – Incidents involving the release or spillage of greater than 10 uCi of a radionuclide or any amount of a radionuclide in a volatile form.

Minor Incident Procedure:

- Notify all other persons in the area immediately.
- Prevent the spread of contamination by placing absorbent paper on the spill.
- Clean up the spill working from the outside of the spill inward.
- Survey the area, record the results.
- Dispose of all materials as radioactive waste.
- Survey clothes, hands, and feet.
- Notify the laboratory supervisor.
- Notify Radiation Safety Officer at 409-880-8276 and EHS & Risk Management at (409) 880-7249.

Major Incident Procedure

- Clear the area of all personnel.
- Notify the Radiation Safety Officer at 409-880-8276.



- Notify the laboratory supervisor.
- Close and lock the laboratory.
- Post warning signs.
- Survey personnel and area, record results.
- Wait for assistance from Radiation Safety officer before decontaminating the area.

Surveys of the area for residual contamination are also required as well as reporting all accidental releases to the Radiation Safety Officer. See the [LU Radiation Safety Manual](#) for more information on managing accidental releases of radioactive materials.

Appendix E: Forms & Checklists

LABORATORY CONTACT INFORMATION*

Department: _____

Lab Manager/Principal Investigator: _____

Phone: _____

Emergency Contact Person: _____

Phone: _____

After Hours Phone: _____

Emergency Responder Contact Information

Call 911 immediately for all fires and any accidents or spills with injuries that require urgent medical attention.

Call EHS & Risk Management, (409) 880-7249, during normal business hours for accidents or spills without injuries or with injuries that do not require urgent medical attention. After normal business hours and on weekends and holidays call LUPD at (409) 880-7777.

Emergencies involving radiation or radioactive materials must be also reported to the **LU Radiation Safety Officer at 409-880-8276**. After normal business hours and on weekends and holidays call **LUPD at (409) 880-7777**.



General Emergency Procedures

Type of Emergency	Who to Call
All Fires Accidents or Spills WITH injuries that require urgent medical attention	At Any Time Campus Police or Local Emergency Responders 911
Accidents or spills WITHOUT injuries, or with injuries that do not require urgent medical attention (e.g. on-site first aid only)	During Normal Business Hours EHS & Risk Management (409) 880-7249 Outside Normal Business Hours, Weekends, Holidays LUPD (409) 880-7777
Emergencies involving radiation or radioactive materials	During Normal Business Hours Radiation Safety Officer 409-880-8276 Outside Normal Business Hours, Weekends, Holidays LUPD (409) 880-7777

* Fill in appropriate information and post on entry door to laboratory and next to the laboratory phone, if one is present. **Always follow up with EHS & Risk Management after any emergency.**



Laboratory Safety Survey Form for P.I.s

<i>Laboratory Safety Survey</i>		<i>Department:</i>
<i>Person Responsible for Lab:</i>		<i>Building/Rooms:</i>
<i>Name of Inspector(s):</i>		<i>Inspection Date:</i>
		<i>(Y)/(N)/(N/A)</i>
		<i>Comments</i>
Chemical Storage & Safety		
1	<i>Chemical containers properly labeled, stored, & closed when not in use.</i>	
2	<i>Chemicals segregated and stored by compatibility.</i>	
3	<i>Peroxide formers dated at purchase and again upon opening</i>	
4	<i>Peroxide formers disposed of within proper time frames.</i>	
5	<i>Secondary containment used where appropriate</i>	
6	<i>Vacuum equipment trapped and/or filtered.</i>	
7	<i>Chemical storage areas free of ignition sources.</i>	
8	<i>Refrigerators/Freezers properly labeled.</i>	
9	<i>Refrigerators/Freezers properly rated if flammable liquids are stored within.</i>	
10	<i>Fume hoods and/or biosafety cabinets not used for general storage.</i>	
11	<i>Cryogenic materials stored properly and proper PPE available.</i>	
12	<i>Flammable liquids in containers over 4 L are in approved safety cans.</i>	
13	<i>Corrosive storage cabinet used if more than 10 gal of corrosives present.</i>	
14	<i>Chemicals purchased in amounts that can be used within a reasonable time.</i>	
15	<i>Chemical stocks purged of old, outdated, and unusable chemicals.</i>	
16	<i>Chemical inventory up to date and copy sent to EH&S.</i>	
Compressed Air and Compressed Gases		
1	<i>Air compressors equipped with pressure gauges and pressure relief valves.</i>	
2	<i>Compressed air piping, hoses and fittings in good condition.</i>	
3	<i>Compressed air 30 psi or less for machine/parts cleaning, 10 psi for clothing.</i>	
4	<i>Compressed air cleaning nozzles with chip/particle deflection device.</i>	
5	<i>Gas cylinders w/30 lb or more water capacity have valve protection capability.</i>	
6	<i>Gas cylinders legibly marked as to their contents.</i>	
7	<i>Gas cylinders stored away from high heat, flames, etc.</i>	



- 8 *Gas cylinders stored in secure area and secured from tipping or falling.*
- 9 *Gas cylinders transported on cylinder carts.*
- 10 *When in use, gas cylinders kept away from elevators, stairs, and ramps.*
- 11 *Valve protectors used when cylinders not in use or when being transported*
- 12 *Liquefied gas cylinders (acetylene) always shipped and stored valve-end up.*
- 13 *Proper type of regulator used for type of gas cylinder in use.*
- 14 *Gas cylinders, valves, couplings, regulators kept free of oil and grease.*
- 15 *Gas cylinders lacking obvious defects, leaks, damage, etc.*
- 16 *Gas cylinders hydrotested at appropriate intervals.*
- 17 *Empty gas cylinders labeled "Empty," valves closed, and caps on.*
- 18 *Gases of different hazard classes are separated by 20 feet or a ½ hour fire wall.*

Hazardous Waste & Materials Disposal and Recycling

- 1 *Waste storage areas (bins, totes) designated.*
- 2 *Waste containers properly labeled (chemical components, amounts, etc.).*
- 3 *Waste containers compatible with waste to be stored.*
- 4 *Only compatible chemical wastes stored in the same container.*
- 5 *Waste containers kept closed except when adding waste.*
- 6 *Waste containers stored compatibly.*
- 7 *Fluorescent, HID, Mercury vapor lamps recycled properly.*
- 8 *Used oil collected and recycled properly.*
- 9 *Non-alkaline batteries (lead acid, Ni-cad, silver, etc.) managed for recycling.*
- 10 *Mercury containing devices (thermostats, barometers, etc.) properly recycled.*
- 11 *Electronic devices, (monitors, TVs, circuit boards, etc.) managed properly.*
- 12 *Biohazardous materials & animal carcasses managed & disposed properly.*

Manuals, Training, SOPs, MSDSs, Occ. Health

- 1 *Appropriate safety manual(s) available (CHP, ECP, Bio Safety Rad Safety, etc.).*
- 2 *Standard Operating Procedures & Material Safety Data Sheets readily available*
- 3 *Applicable initial/refresher training completed. (LS,HW,BW,BBP, RAD,etc.).*
- 4 *Personnel in occ. health program, if required (blood, etiologic agents, carcin.).*

Safety Equipment and Emergency Preparedness



1 *Eyewash & safety shower within 100 ft. and 10 second travel time.*

- 2** *Eyewash & safety shower unobstructed and inspected as required.*
- 3** *Fume hoods, biosafety cabinets, glove boxes, properly located and certified.*
- 4** *Appropriate spill control kit available and stocked (Chem, Rad, Bio).*
- 5** *Spill & accident reporting procedures understood by lab personnel.*
- 6** *Appropriate first aid kit available and stocked.*
- 7** *Emergency contact information posted by entrance (and by phone if present).*
- 8** *Laboratory under negative pressure in relation to other areas.*

Electrical Safety

- 1** *Extension cords are not used as permanent wiring.*
- 2** *Extension cords and power strips not daisy-chained one to another.*
- 3** *Electrical cords not under carpets/rugs, through doorways, or high traffic areas.*

- 4** *Multi-outlet power strips are UL listed and have circuit breakers.*
- 5** *Power cords are in good condition with no splices or broken insulation.*
- 6** *Grounding prongs not removed from 3-way plugs.*
- 7** *Outlet, switch and junction box covers are in place and in good repair.*
- 8** *Circuit breaker panels and emergency shut offs unobstructed and labeled.*
- 9** *Electrical outlets not overloaded with appliances, i.e. splitters used.*
- 10** *Ground Fault Interrupters installed, labeled and operating correctly.*
- 11** *Energized parts, circuits, and equipment guarded against accidental contact.*

Fire Prevention and Protection

- 1** *Fire extinguishers properly mounted, located, and identified.*
- 2** *Fire extinguishers adequate in number and type.*
- 3** *Fire extinguishers inspected, recharged, and maintained as required.*
- 4** *Fire aisles, exit ways, stairways, and fire equipment kept unobstructed.*
- 5** *Exit lights properly illuminated and emergency lighting operable.*
- 6** *Fire doors not blocked open or are on magnets connected to fire alarm system.*

- 7** *Flammable liquids stored in approved safety cans.*
- 8** *Flammable liquid containers kept closed when not in use.*
- 9** *Flammable liquids of 10 gallons or more stored in flammable storage cabinet.*



- 10 *Flammable storage cabinets labeled "Flammable - Keep Fire Away."*
- 11 *Connections on drums and combustible liquid piping leak free.*

- 12 *Flammable liquid drums grounded and bonded to containers when dispensing.*
- 13 *Flammable/combustible materials properly stored to reduce risk of fire.*
- 14 *Oily/greasy rags placed in proper self-closing oily rag containers.*
- 15 *No penetrations through walls or ceilings and all ceiling tiles are in place.*
- 16 *Sprinkler heads clean and no storage within 18 inches/24 inches.*
- 17 *Sprinkler heads protected by metal guards when exposed to physical damage.*

General & Miscellaneous Safety

- 1 *Hand washing sink, soap and towels available & used before leaving lab.*
- 2 *Sink faucets with backflow device or attached hoses above sink rim.*
- 3 *Heavy objects stored below 5 ft. unless secured and stepladder provided.*
- 4 *Stepladder or stepstool available & in good condition for high storage access.*
- 5 *Appropriate signs posted (First aid kit, safety shower, fire extinguisher, etc.).*
- 6 *Proper handling & disposal of broken glass & sharps.*
- 7 *Batteries charged in properly ventilated area away from sparks and flames.*
- 8 *Work practices observed during inspection done safely.*
- 9 *No food or beverages unless adequately separated from hazard areas.*
- 10 *Bench tops impervious to water and resistant to chemicals.*
- 11 *Lab furniture is appropriate for loading and use.*

General Work Environment & Indoor Air Quality

- 1 *All areas properly illuminated. Glare and reflections avoided.*
- 2 *Noise levels are within acceptable limits or engineering controls established.*
- 3 *Areas with high noise levels posted and hearing protection required to be used.*
- 4 *Work areas clean, sanitary, and orderly. (garbage disposed properly, etc.)*
- 5 *Work area properly ventilated for type of equipment or chemicals in use.*
- 6 *Vacuum systems used when possible instead of blowing or sweeping dusts.*
- 7 *Temperature and humidity seem to be within acceptable ranges.*
- 8 *Areas free of visible fungal/mold growth and associated odors.*
- 9 *Walls, ceilings, floors free of signs of mold or moisture damage.*
- 10 *Air intake areas free of odor causing materials or hazardous chemicals.*



Personal Protective Equipment (PPE)

1 ***Appropriate eye/face protection is available and used if hazard present.***

2 ***Appropriate hand protection is available and used if hazard present.***

3 ***Appropriate hearing and foot protection available and used if hazards present.***

4 ***Protective clothing - coveralls, aprons, gowns, etc. available & used if needed.***

5 ***Protective clothing and gloves removed before leaving lab.***

6 ***Non-disposable protective clothing laundered on site or by commercial service.***

7 ***Approved respirators available and used if needed.***

8 ***Respirator users medically certified, properly trained and fit tested.***

9 ***PPE is properly stored, clean and in good condition.***

Animal Biological Safety Level 2

1 ***Personnel are enrolled in the Occupational Health Program.***

2 ***Human allergies to animals have been addressed.***

3 ***If animals are taken from the animal care facility & used in the lab, how long?***

4 ***Project has been approved by the IACUC.***

5 ***Floor drain traps filled with disinfectant.***

Biological Safety Level 2

1 ***Lab access restricted when working with infectious agents.***

2 ***Appropriate Biological Safety Level sign posted.***

3 ***Lab personnel advised of hazards and required immunizations.***

4 ***Lab personnel receive appropriate immunizations & tests for agents handled.***

5 ***Baseline serum collected, if appropriate.***

6 ***Specimen containers leak-proof and covered during transport.***

7 ***Equipment & work surfaces disinfected regularly, after work with agents or spills.***

8 ***Work has been approved by the IBC.***

9 ***Access restricted to Select Agents and Select Agents properly secured.***

10 ***All spaces accessible for cleaning and are easily cleaned. No carpets or rugs.***

11 ***Insect and rodent control program in place.***



- 12 *Biosafety Cabinet (Class II) or other containment device used when appropriate.*
- 13 *Centrifuge safety caps/cups are utilized.*
- 14 *Mechanical pipetting devices are utilized.*

- 15 *Autoclave efficacies are verified & documented.*
- 16 *Plastic ware and safer needle alternatives implemented where feasible.*

Biological Safety Level 2 +

- 1 *BSL 3 Standard practices, special practices, and safety equipment in use.*
- 2 *Laboratory is under negative pressure with respect to other areas.*
- 3 *Exhaust air is discharged to the outside of the building.*
- 4 *Hands-free/automatic hand washing sink provided near exit door.*
- 5 *Vacuum lines protected with liquid disinfectant traps and HEPA filters.*

Radiation Safety

- 1 *Room is authorized by LU's State of Texas Radioactive Materials License*
- 2 *Caution, Radioactive Material signs posted on entrance doors (64E-5.322)*
- 3 *Equipment, containers, & storage areas properly labeled (64E-5.325, .1316(7))*
- 4 *Emergency procedures posted (64E-5.901(1)(f))*
- 5 *Notice to Employees (Form DH-1081) posted. (64E-5.901(3))*
- 6 *EH&S Waste Guidelines posted*
- 7 *Radioactive material secured against unauthorized access/removal (64E- 5.320)*
- 8 *Appropriate shielding of radioactive materials (64E-5.303(2))*
- 9 *Radioactive material users have received initial training (64E-5.1307)*
- 10 *Radioactive material users have received refresher training*
- 11 *Inventory records are maintained for 3 years (64E-5.303)*
- 12 *Survey records are maintained for 3 years (64E-5.1319(3), .336)*
- 13 *Survey instrument available (64E-5.1318(1)(3))*
- 14 *Survey instrument calibrated within the last year (64E-5.314(2))*
- 15 *Liquid Scintillation Counter calibrated annually (64E-5.314(2))*
- 16 *Waste is properly labeled (64E-5.1316(6))*
- 17 *Waste is properly shielded (64E-5.1316(5))*



- | | |
|-----------|--|
| 18 | <i>Removable contamination surveys performed as required (64E-5.314, .1319)</i> |
| 19 | <i>Radiation level surveys performed at required frequency (64E-5.1319(1))</i> |
| 20 | <i>Radioactive materials users wear appropriate PPE (64E-5.1316(1)(2))</i> |
| 21 | <i>Fume hood functioning properly (64E-5.1317)</i> |
| 22 | <i>Individuals wear whole body TLDs as required (64E-5.1316(5), .1310(4)(5)(6))</i> |

- | | |
|-----------|--|
| 23 | <i>Individuals wear extremity TLDs as required</i> |
| 24 | <i>No evidence of eating, drinking, or applying cosmetics (64E-5.1316(3))</i> |
| 25 | <i>No storage of food, drink, or personal effects in restricted area (64E- 5.1316(4))</i> |
| 26 | <i>No radioactive contamination detected</i> |
| 27 | <i>Radiation levels less than 2 mR in any one hour 27</i> |



Appendix F: Glossary

Laboratory employees should become familiar with the following terms and concepts. Many of these terms are commonly used in Safety Data Sheets (SDSs). Some are also found in this Chemical Hygiene Plan.

ACGIH. American Conference of Governmental Industrial Hygienists. An organization of professionals in government agencies and educational institutions engaged in occupational safety and health programs.

aqueous. Describes a water-based solution or suspension. Frequently describes a gaseous compound dissolved in water.

anhydride. Any compound formed by the removal of the elements of water (hydrogen and oxygen).

anhydrous. "Without water". A substance in which no water molecules are present either in the form of a hydrate or as water of crystallization.

ANSI. American National Standards Institute. A privately funded, voluntary organization which develops and coordinates national consensus standards. Many ANSI standards relate to safe design/performance of equipment and safe practices or procedures. ANSI standards are widely recognized and accepted as "State of the Art" knowledge regarding acceptable safety practices.

asphyxia. The loss of consciousness as a result of too little oxygen and too much carbon dioxide in the blood.

asphyxiant. A vapor or gas that can cause unconsciousness or death by suffocation. Most *simple asphyxiants* are harmful to the body only when they become so concentrated that they reduce the available oxygen in the air (normally about 21 %) to dangerous levels (18 % or lower); e.g., CO₂, N₂, H₂ and He. Others are *chemical asphyxiants* like carbon monoxide (CO) or hydrogen cyanide (HCN) which reduce the blood's ability to carry oxygen.

autoignition temperature. The minimum temperature to which a substance must be heated without application of a flame or spark to cause that substance to ignite. Materials should not be heated to greater than 80% of this temperature.

base. A substance that can do at least one of the following: (1) liberate hydroxide anions (OH⁻) when dissolved in water, (2) receive a hydrogen ion from a strong acid to form a weaker acid, and/or (3) give up two electrons to an acid. Bases have a pH > 7 and turn litmus paper blue. They may be corrosive to human tissue and should be handled with care.

biodegradable. The capability of being readily decomposed by biological means, especially by microorganisms.

biomedical waste. Any solid or liquid waste which may present a threat of infection to humans.

biomedical waste disposal bags (red bags). These are the biomedical waste disposal bags used at LU, to comply with 29 CFR 1910.1030(g)(1), and Texas law that refers to same. Supplies of these bags can be obtained from approved vendors.

Bloodborne Pathogens Policy and Procedures. The University's Exposure Control Plan, designed to eliminate or minimize occupational exposure of employees to bloodborne pathogens and other potentially infectious materials in compliance with OSHA's Bloodborne Pathogens Standard [29 CFR 1910.1030](#).

boiling point, BP. The temperature at which the vapor pressure of a liquid is equal to the surrounding atmospheric pressure so that the liquid becomes a vapor. Flammable materials with low BP's generally present special fire hazards. e.g., butane, BP = 31 °F; gasoline, BP = 100°F.

BTU. British thermal unit. The quantity of heat required to raise the temperature of 1 lb of H₂O by 1 °F at 39.2 °F, its temperature of maximum density.

buffer. A substance that reduces the change in hydrogen ion concentration (pH) that otherwise would be produced by adding acids or bases to a solution.

carcinogen. Substances that can cause cancer in humans or animals. A material is considered to be a carcinogen if (1) it has been evaluated and listed by the International Agency for Research on Cancer (IARC), (2) it is listed as a carcinogen or suspected carcinogen in the [Annual Report on Carcinogens](#) published by the National Toxicology Program (NTP), (3) it is regulated by OSHA as a carcinogen, or (4) it meets the EPA criteria for a carcinogen or suspected carcinogen.

CAS Registration Number. Chemical Abstract Service registration number is the number assigned to identify a substance. CAS numbers identify *specific* chemicals and are assigned sequentially. The numbers have no chemical significance.

CFR. Code of Federal Regulations. The annual accumulation of executive agency regulations that contains the general body of regulatory laws governing practices and procedures performed by federal administrative groups.

combustible. A term used by NFPA, DOT, and others to classify, on the basis of flash point, certain liquids that will burn.

corrosive. A chemical that causes visible destruction or irreversible alterations in living tissue through chemical action at the site of contact.

cryogenic. Relating to extremely low temperature such as in refrigerated gases.

TCEQ. The Texas Commission on Environmental Quality. A state agency with environmental protection, regulatory, and enforcement authority.

dermal toxicity. Adverse effects resulting from skin exposure to a material. Ordinarily used to denote effects on experimental animals.

DOT. U.S. Department Of Transportation. Regulates transportation of materials. DOT addresses issues in labeling, weight, classification of hazards, placarding of vehicles, etc. DOT regulations are intended to protect the public as well as fire rescue, EMTs and other emergency-response personnel.

Designated Area. A separate and distinct portion of a laboratory designed to deal with extremely hazardous chemicals and other substances that require special considerations. The Designated Area must have the necessary engineering controls (fume hoods, biosafety cabinets, etc.) and the appropriate warning labels. Access must also be strictly controlled. A Standard Operating Procedure detailing the methods, responsible individuals, materials and handling of substances in the Designated Area must be completed by the Principal Investigator, and approved by **EH&S**.

electrolyte. Any substance which in solution or in a liquid form is capable of conducting an electric current by the movement of its disassociated positive and negative ions to the electrodes.

EPA. U.S. Environmental Protection Agency. The federal agency with environmental protection, regulatory, and enforcement authority.

evaporation rate. The rate at which a material will vaporize from the liquid or solid state. The evaporation rate can be useful in evaluating the health and fire hazards of a material.

exposure limits. The boundaries for quantities of chemicals to which employees can be exposed.

flammable. Describes any solid, liquid, vapor or gas that will readily catch fire and burn in air.

flash point. The lowest temperature at which a liquid has a sufficient vapor pressure to form an ignitable mixture with air near the surface of the liquid.

freezing point. The temperature at which a material changes its physical state from liquid to solid.

hazardous material. Any substance or mixture of substances having which has properties capable of producing adverse effects on the health or safety of a human. These substances also display the characteristics stated in 40 CFR 261.3, Subpart D, of ignitability, corrosivity, reactivity and EPA Toxicity or are listed in 40 CFR 261.31-33.

HEPA. Acronym for **H**igh-**E**fficiency **P**articulate **A**ir-purifying filter equipment, used for removing airborne materials. Often used for the removal of infectious microbes (e.g., TB) from the air.

incompatible. Describes materials that can cause dangerous conditions when mixed together or stored in close proximity.

irritant. A non-corrosive material which causes a reversible inflammatory effect on living tissue at the site of contact. The severity of the reaction is a function of concentration and duration of exposure.

LEL. Lower Explosive Limit refers to the minimum concentration (by percent volume) of a fuel (vapor) in air at which a flame is propagated when an ignition source is present.



melting point. The temperature at which a solid changes to liquid.

(M)SDS. (Material) Safety Data Sheet. These sheets contain descriptive safety information concerning the use and handling of chemicals. OSHA has established guidelines for these forms (OSHA form 174) and requires those who produce, distribute, and use hazardous materials to make the MSDS available to their employees. *In 2012, the acronym 'MSDS' was simplified to 'SDS', which stands for Safety Data Sheet – see the definition of SDS for more information.*

mutagen. A material that induces genetic changes (mutations) in the DNA of chromosomes.

nanomaterial. Engineered nanoscale materials or nanomaterials are materials that have been purposefully manufactured, synthesized, or manipulated to have a size with at least one dimension in the range of approximately 1 to 100 nanometers and that exhibit unique properties determined by their size.

nanoparticle. An ultrafine particle with lengths in two or three dimensions greater than 0.001 micrometer (1 nanometer) and smaller than about 0.1 micrometer (100 nanometers) and which may or may not exhibit a size-related intensive property.

NFPA. National Fire Protection Association. A national organization with the purpose of establishing programs, standards and safeguards against loss of life and property by fire. The NFPA develops the National Fire Codes that are commonly used as model codes in the laws that govern fire prevention and protection.

NIOSH. National Institute of Occupational Safety and Health. The agency of the Public Health Service that tests and certifies respiratory and air sampling devices. It recommends exposure limits for substances and assists OSHA in investigations and research.

odor threshold. The lowest concentration of a gas in air that can be detected by smell.

OSHA. The Occupational Safety and Health Administration. Part of the U.S. Department of Labor. The regulatory and enforcement agency responsible for safety and health in most U.S. industrial sectors.

oxidation. The process by which electrons are removed from atoms or ions. A common example is a reaction in which a substance combines with oxygen provided by an oxidizer or oxidizing agent.

oxidizer. A substance that readily strips electrons from other atoms or ions. Common hazardous examples often yield oxygen readily to stimulate the combustion (oxidation) of organic matter.

pH. The value that represents the acidity or alkalinity of an aqueous solution. The number represents the base 10 logarithm of the reciprocal of the hydrogen ion concentration of a solution.



physical state. The condition of a material; i.e., solid, liquid, or gas, at a given temperature.

reducing agent. A chemical or substance that (1) has oxygen removed or (2) gains electrons from an oxidation-reduction reaction

REL. Recommended Exposure Limit. The NIOSH REL is the highest allowable airborne concentration that is not expected to injure a worker. It may be expressed as a ceiling limit or as a time-weighted average for 10-hr work shifts.

SDS. Safety Data Sheet. The information contained in the SDS is largely the same as the MSDS, except now the SDSs are required to be presented in a consistent user-friendly, 16-section format. The SDS must be in English (although it may be in other languages as well). In addition, OSHA requires that SDS preparers provide specific minimum information as detailed in Appendix D of 29 CFR 1910.1200.

sensitizer. A material to which there is little or no physiological response on first exposure in humans or test animals. However, repeated exposures may cause a marked response not necessarily limited to the contact site. The skin and respiratory tracts are the most commonly affected areas in the body by chemicalsensitizers.

sharps container. A rigid, puncture-resistant container designed primarily for containment of needles, syringes, lancets, razor blades, etc. All sharps containers must be labeled with international biohazard symbol. All sharps containers must be approved by **EH&S**.

Standard Operating Procedure (SOP). Procedures which outline the methods, responsible individuals, materials and handling of hazardous and toxic substances in a specialized area in the laboratory. An SOP is specifically required when using extremely hazardous chemicals and/or some types of infectious agents.

specific gravity. The ratio of the mass of a body to the mass of an equal volume of water at 4°C or other specified temperature.

target organs. Organs within the body which are specifically affected by different types of chemicals. The most common of these include the liver, kidneys, nervous system, skin, and eyes.

TC_{Lo}. Toxic Concentration Low. The lowest concentration of a substance in air to which humans or animals have been exposed for any given period of time that has produced (1) toxicity, (2) tumorigenesis, or (3) reproductive changes.



TLV. Threshold Limit Value. A term used by ACGIH to express the daily exposure limit for workers to the airborne concentrations of specified materials without adverse effects. ACGIH expresses TLV's in three ways:

- (1) **TLV-TWA**, the allowable **T**ime-**W**eighted **A**verage concentration for a normal 8-hour workday or 40-hour week;
- (2) **TLV-STEL**, the **S**hort **T**erm **E**xposure **L**imit or maximum concentration for a continuous exposure period of 15 minutes (with a maximum of four such periods per day, and provided that daily TLV-TWA is not exceeded); and
- (3) **TLV-C, Ceiling**, the concentration that should not be exceeded at any time.

toxic. Describes the ability of a material to injure biological tissue.

UEL. Upper Explosive Limit refers to the highest concentration (by percent volume) of a fuel (vapor) in air at which a flame is propagated when an ignition source is present.

vapor pressure. The pressure at any given temperature of a vapor in equilibrium with its solid or liquid form. Vapor pressures are useful (with evaporation rates) to determine how quickly a material becomes airborne and thus how quickly a worker can be exposed to it.

volatility. Measure of a material's tendency to vaporize or evaporate at ambient conditions.

water reactivity. Ability of a material to react with water and release a gas that is either flammable or presents a health hazard.



Appendix G: Diagrams of Local Exhaust Devices

G-1 Conventional Fume Hood

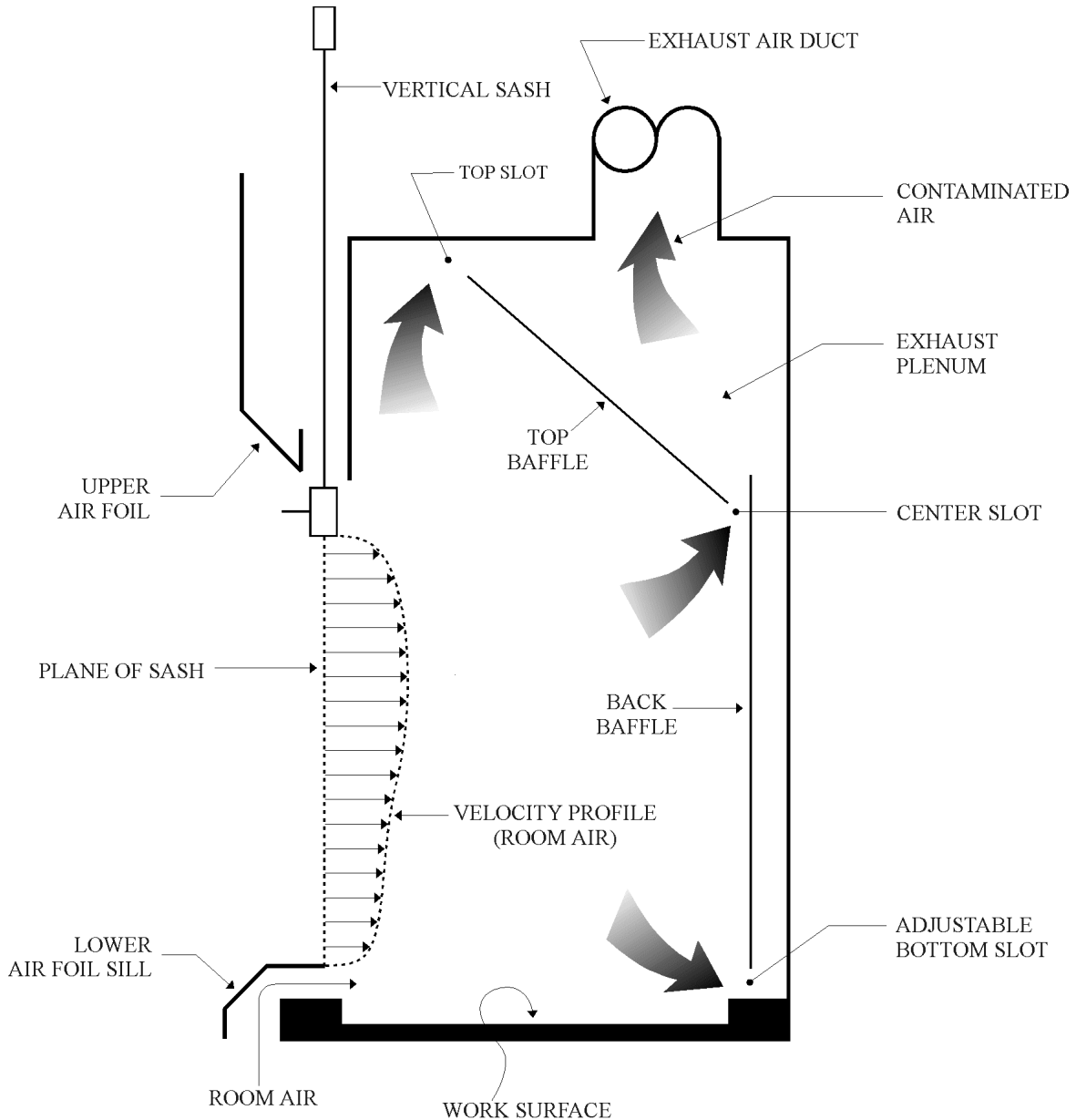

This is the basic fume hood model. Room air is drawn into the hood through the plane of the sash and exhausted through ductwork outside the building. The vertical sash determines the air velocity measured in lfpm (linear feet per minute). The air is exhausted through three (or more) slots (top, center, and bottom) to accommodate a variety of research activities.



G-2 Bypass Fume Hood

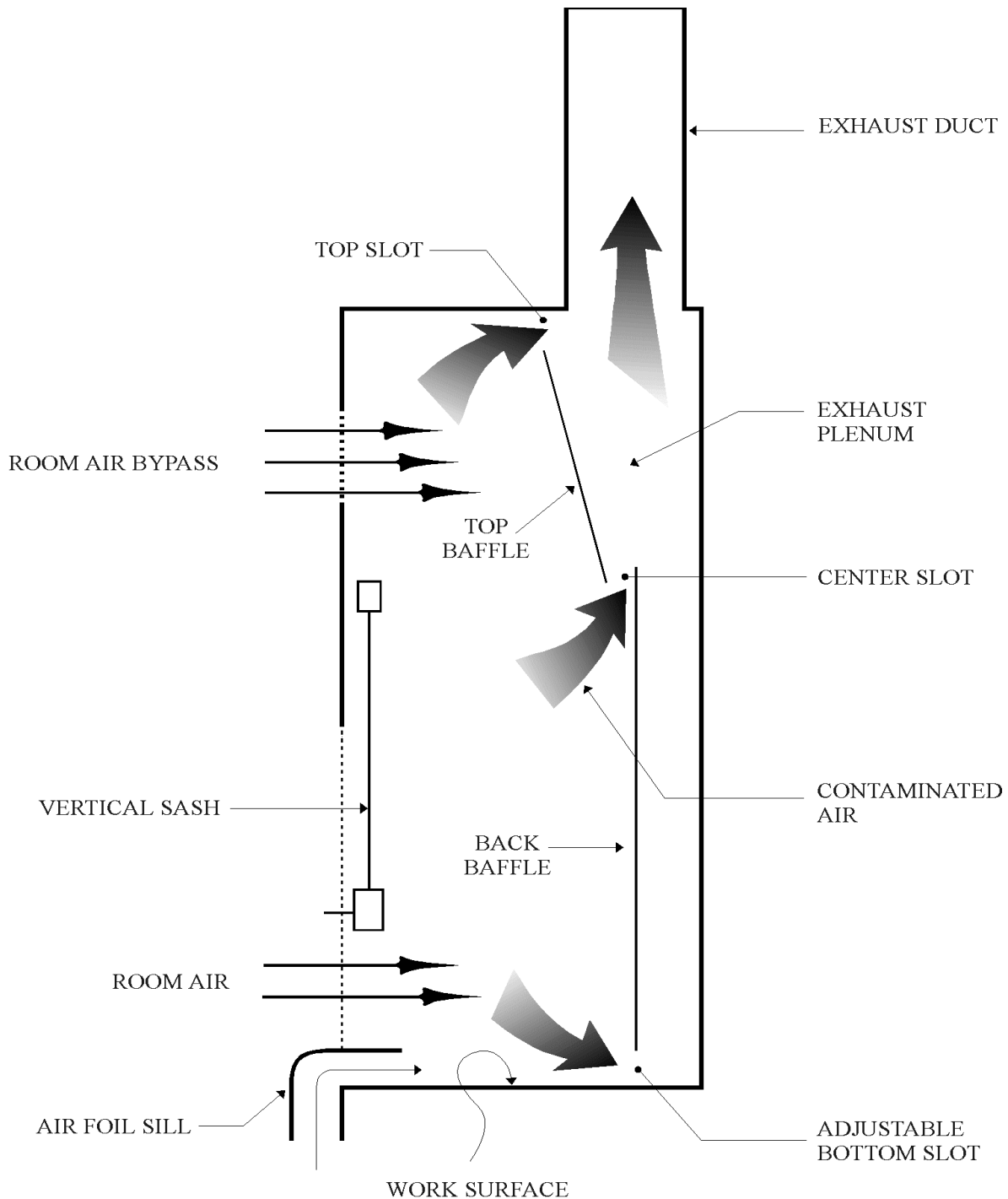

This type of fume hood is designed to minimize the excessive air velocities which occur when the vertical sash opening is low (6 in. or less). Airflow can be diverted through the room-air bypass at low sash openings which decreases the turbulence created by the increased velocities without effecting the efficiency of the fume hood. These hoods are generally used with experiments involving delicate procedures and/or sensitive equipment.



G-3 Auxiliary-Air Fume Hood

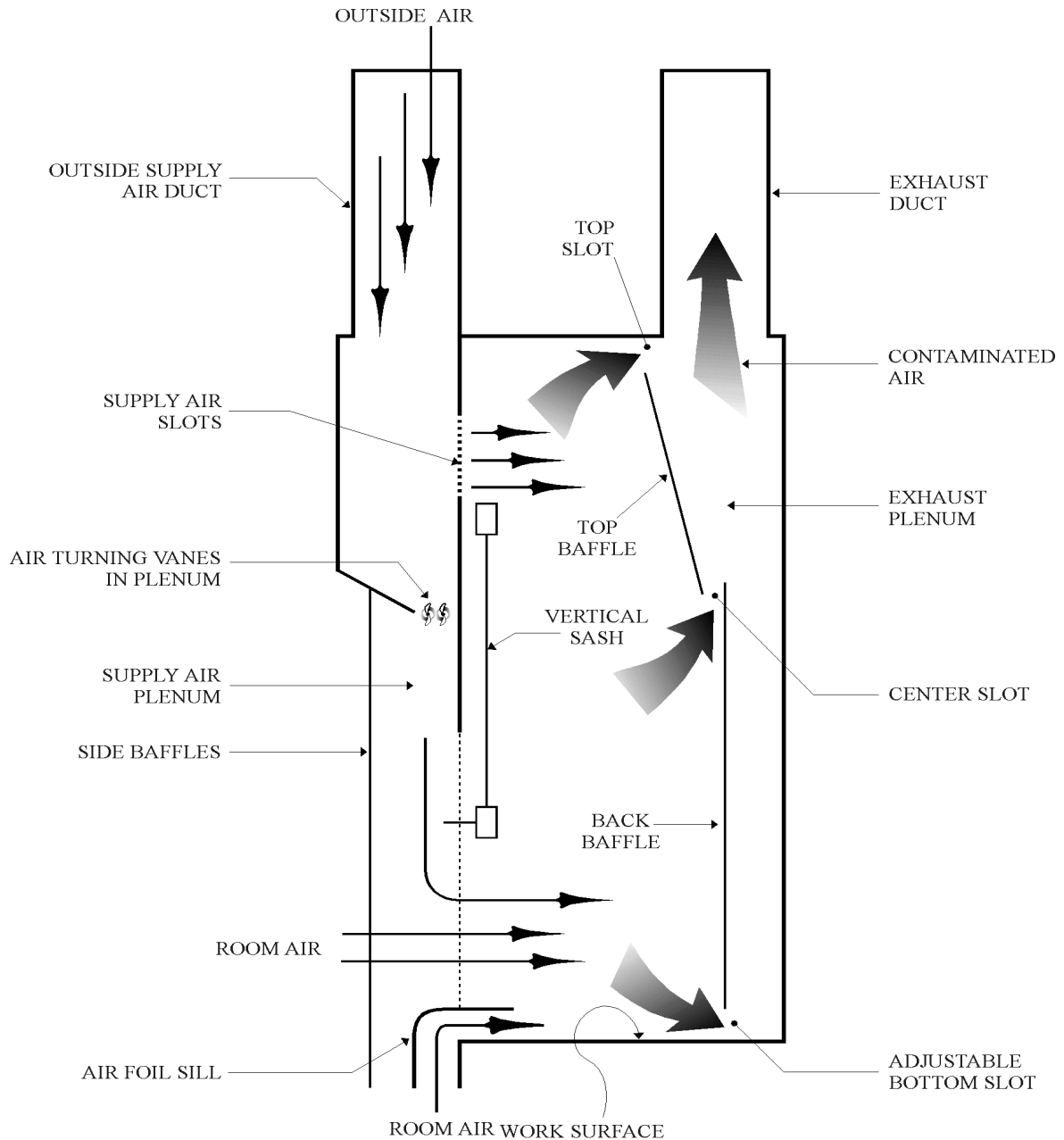

This type of fume hood is similar to the bypass chemical fume hood except that a major portion of the air exhausted is provided from a supply-air plenum attached to the hood just above the face. The purpose of an auxiliary-air fume hood is to reduce the demand for fully conditioned make-up air for hood service. Since the plenum provides streams of minimally conditioned outside air across the face of the hood, users sometimes mistake these airflows as problems with the exhaust of the hood.



Biological Safety Cabinets (BSC)

G-4 Class I BSC

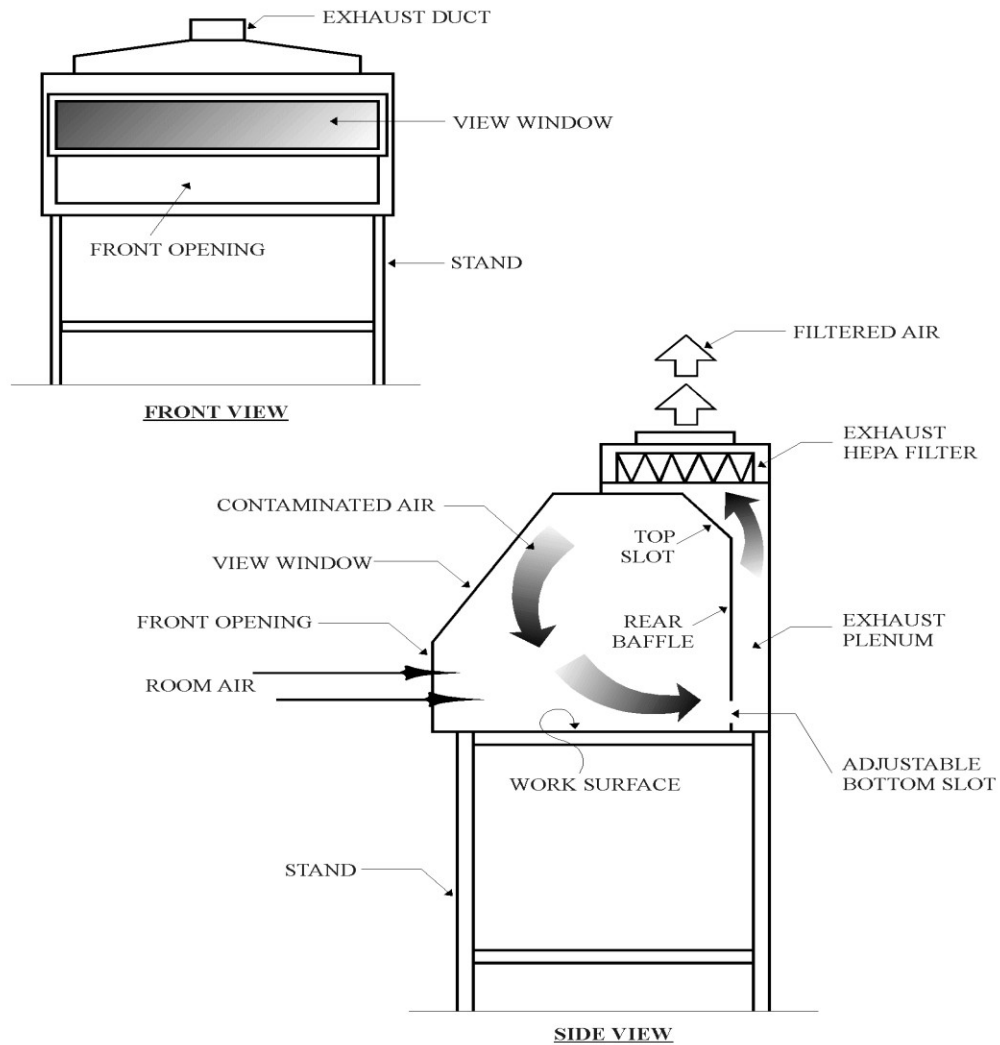

This type of BSC resembles a chemical fume hood with a filtered exhaust. Contaminated air is filtered and either exhausted in the room or ducted outside the building. Class I BSCs are suitable for work with low and moderate risk biological agents where no product protection is required.



G-5 Class II A BSC

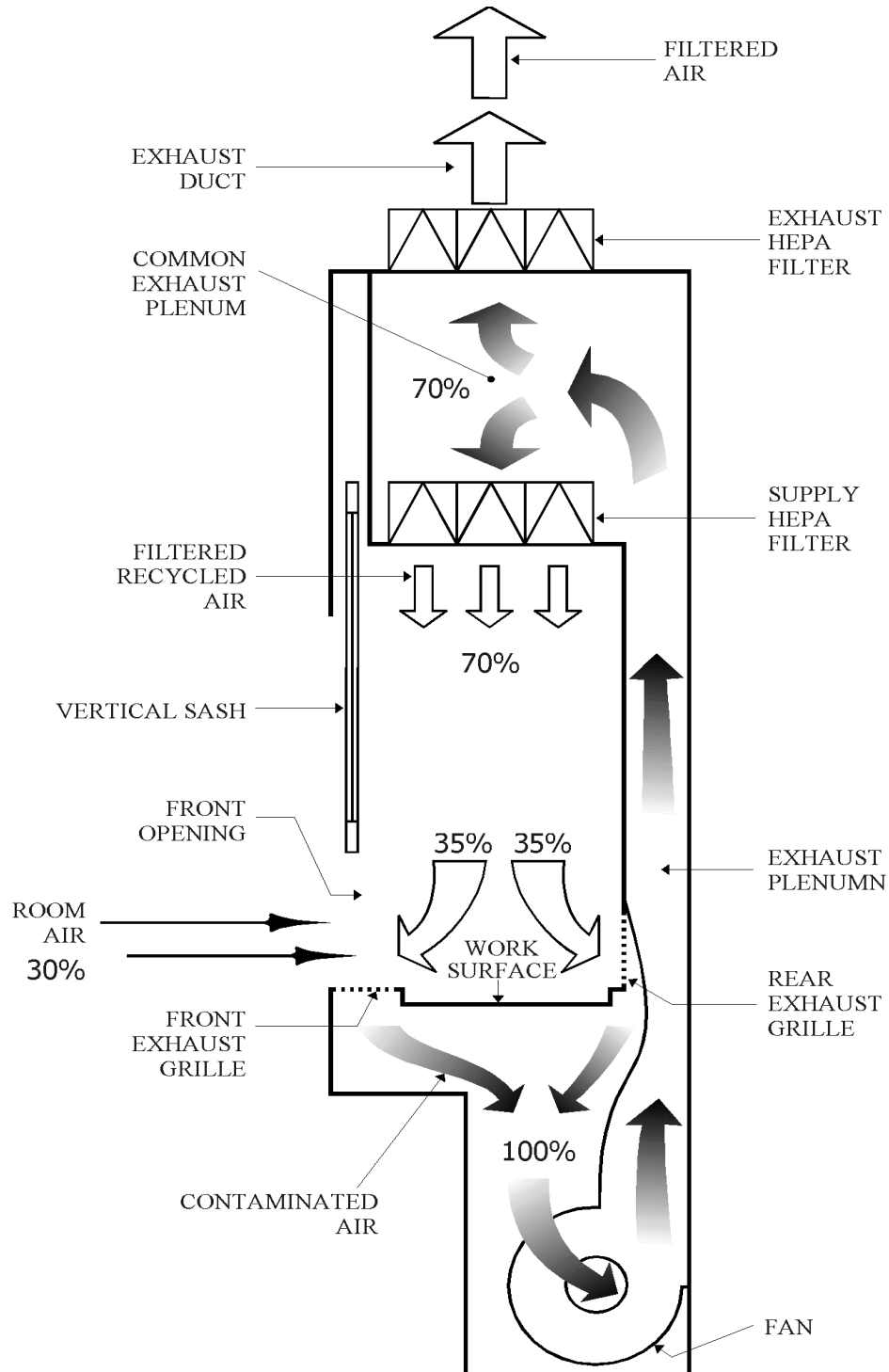

This type of BSC has HEPA-filtered downflow air from a common plenum (filtered recycled air) on the work area and has filtered air exhausted back into the room. Class II A BSCs are suitable for use with low to moderate risk biological agents in the absence of volatile toxic chemicals and volatile radionuclides.



G-6 Class II B1 BSC

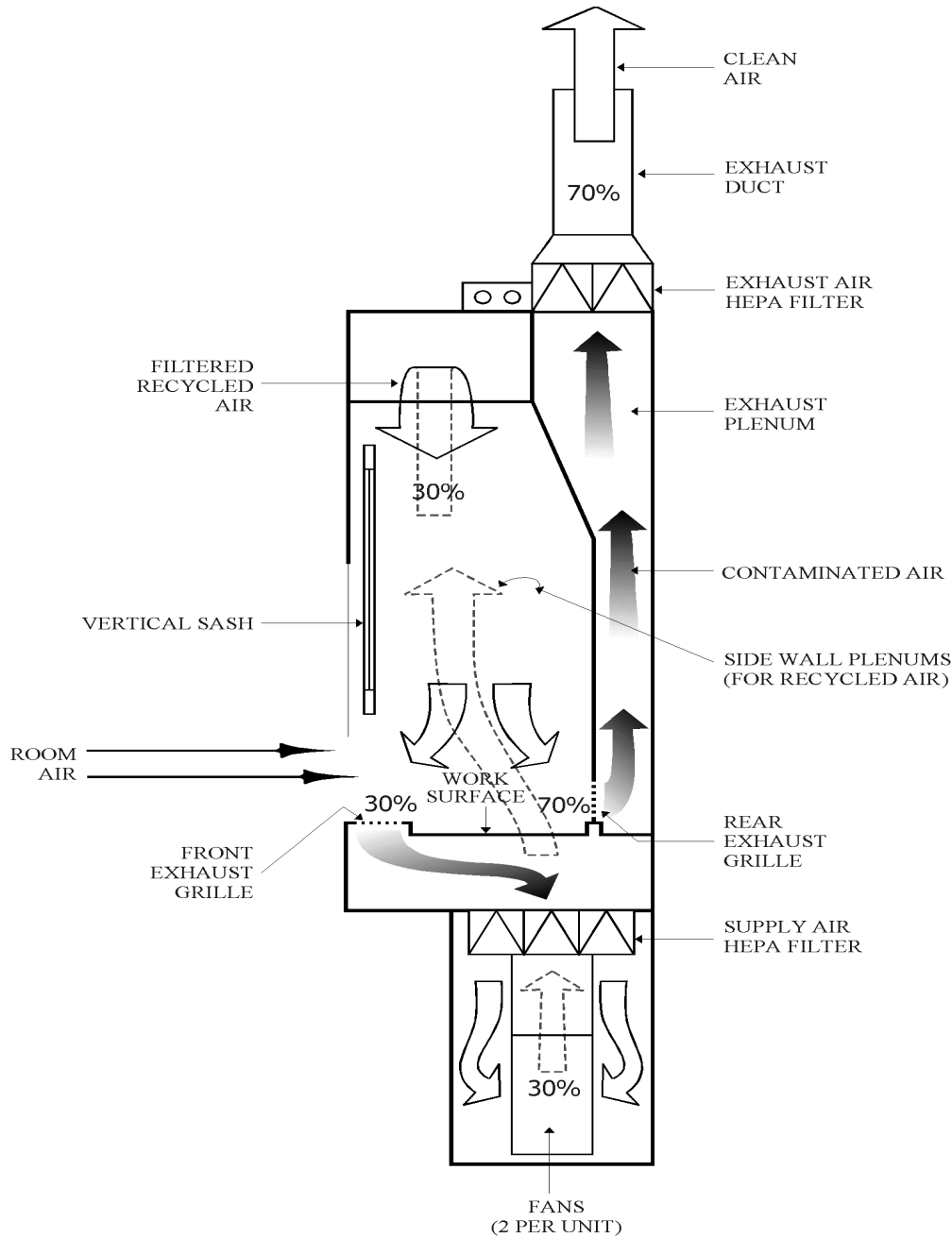

This type of BSC has largely uncontaminated recirculated downward airflow on the work area and removes most of the contaminated downflow air through a dedicated HEPA-filtered exhaust which is ducted to the outside atmosphere. Class II B1 BSCs can be used with low to moderate risk biological agents. They may also be used with biological agents treated with small quantities of chemicals or trace amounts of radionuclides if work is done in the direct exhaust portion of the cabinet (near the rear exhaust grille).



G-7 Class II B2 BSC

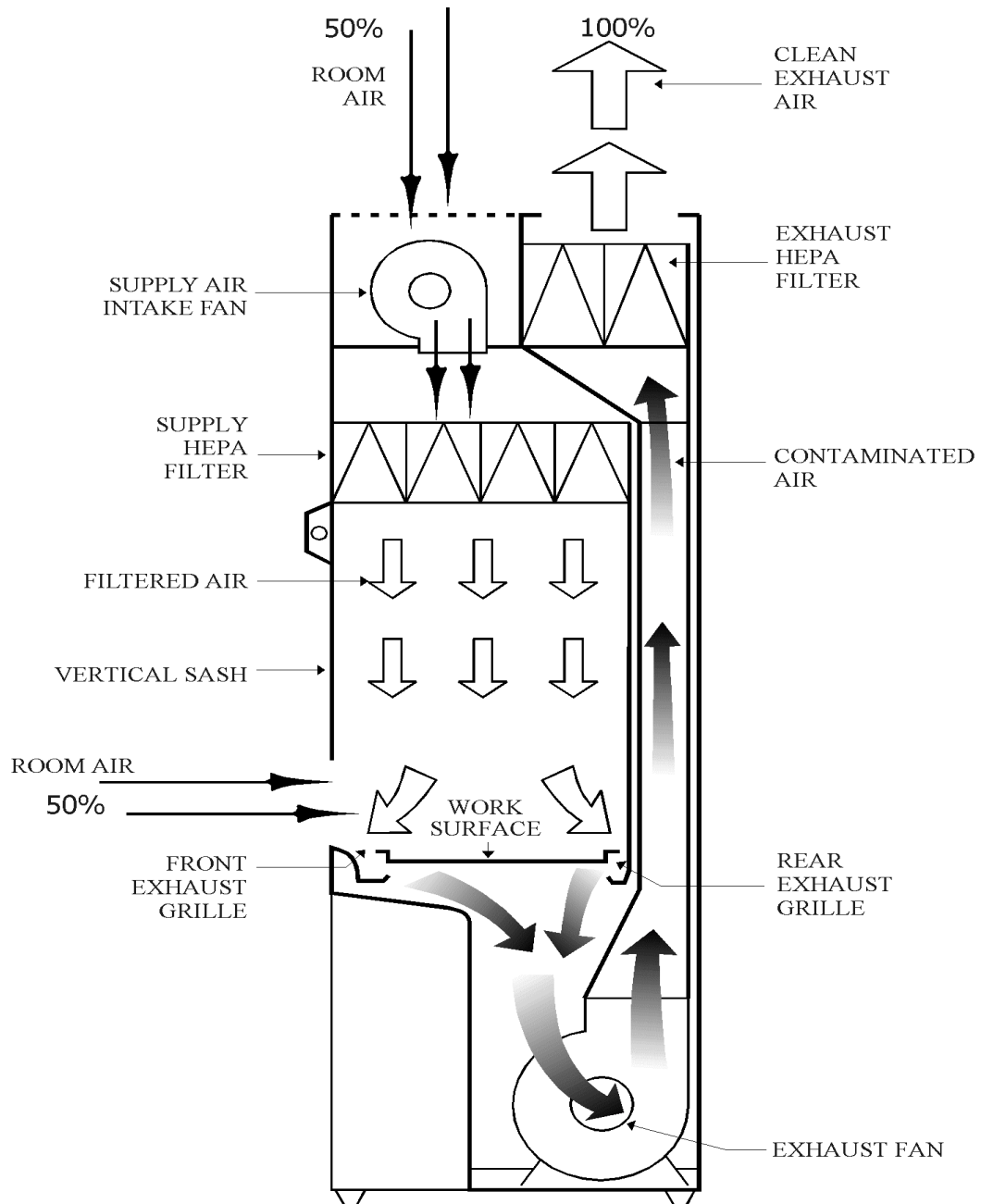

This type of BSC is also known as the “total exhaust” BSC. These cabinets have downward HEPA-filtered airflow on the work area which is drawn from the room (non-recirculated). 100% of the contaminated air is also removed through HEPA-filtered exhaust ducts outside the building. Class II B2 BSCs can be used with low to moderate risk biological agents including those which have been treated with toxic chemicals and radionuclides.



G-8 Class II B3 BSC

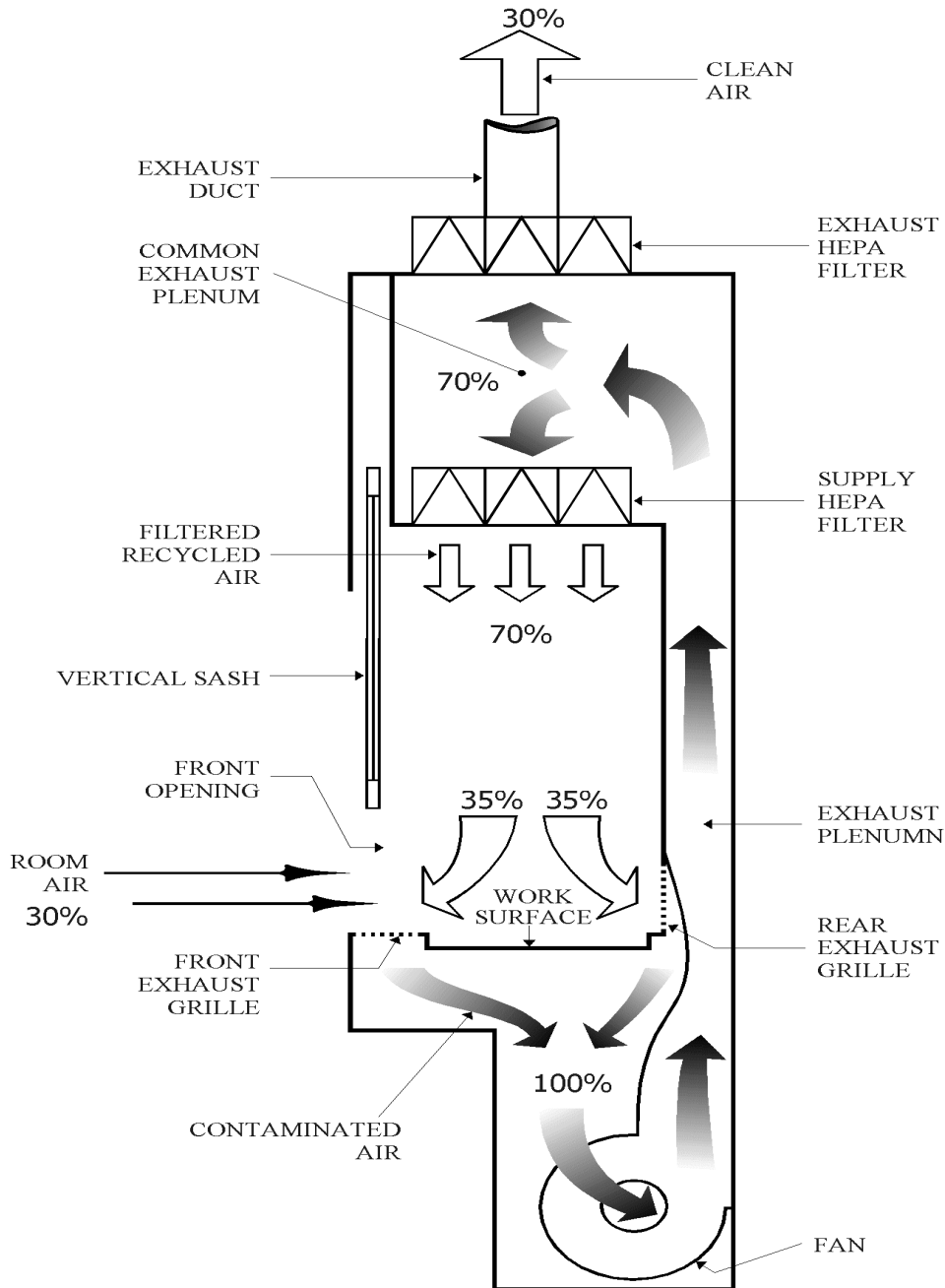

This type of BSC has HEPA-filtered downward airflow on the work area which is a portion of the mixed downflow and inflow air in the common exhaust plenum. These cabinets have all contaminated air removed through a HEPA-filtered exhaust duct to the outside. Class II B3 BSCs can be used with low to moderate risk biological agents including those which have been treated with toxic chemicals and radionuclides.



G-9 Class III BSC

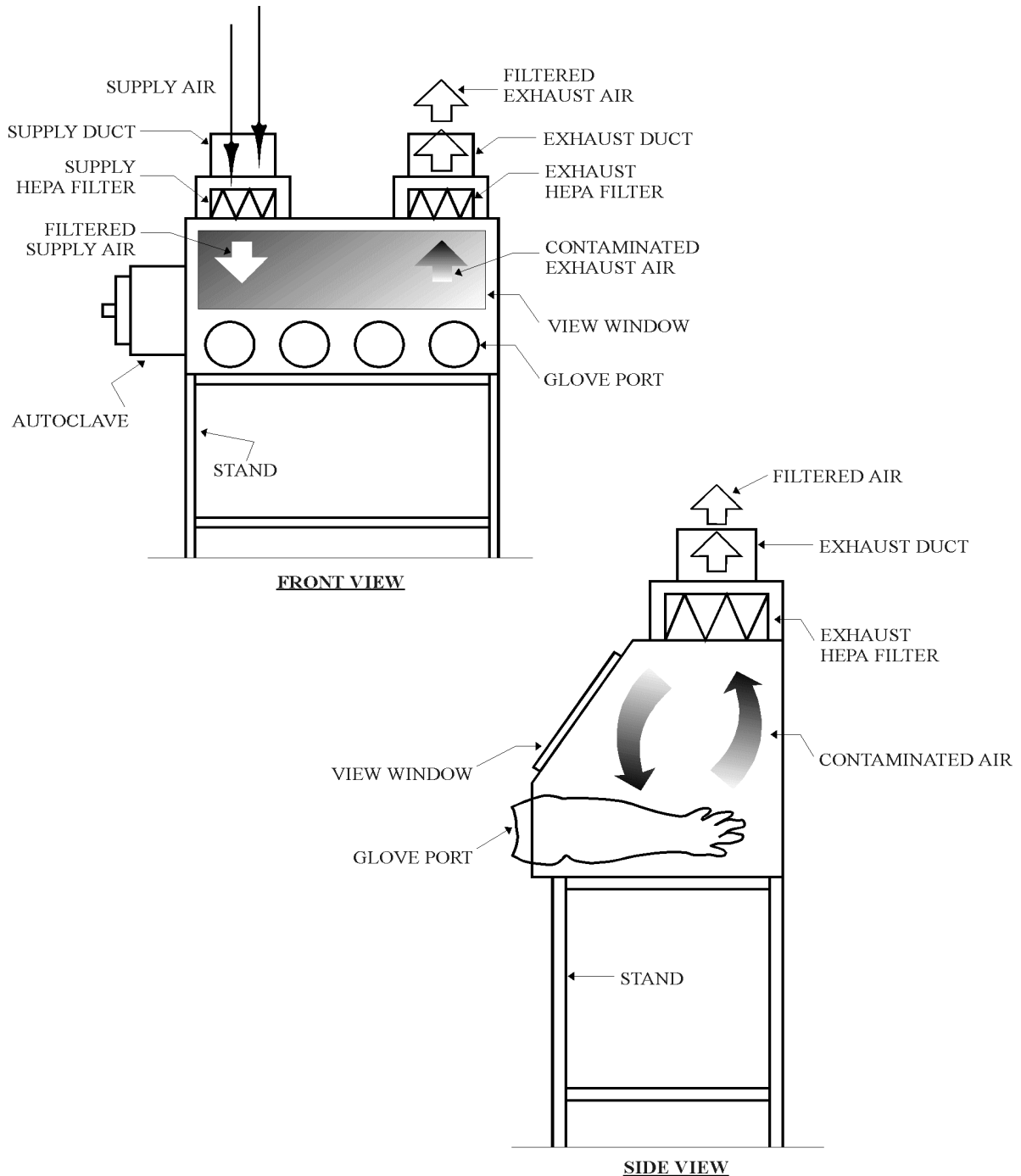

This type of BSC is securely closed and gas tight. Work is conducted through glove ports and the operator has no direct contact with the samples studied. Supply and exhaust air are HEPA-filtered. Class III BSCs are suitable for use with high-risk biological agents and are accompanied by a variety of auxiliary safety equipment.



Laminar Flow Hoods

G-10 Horizontal Laminar Flow Hood

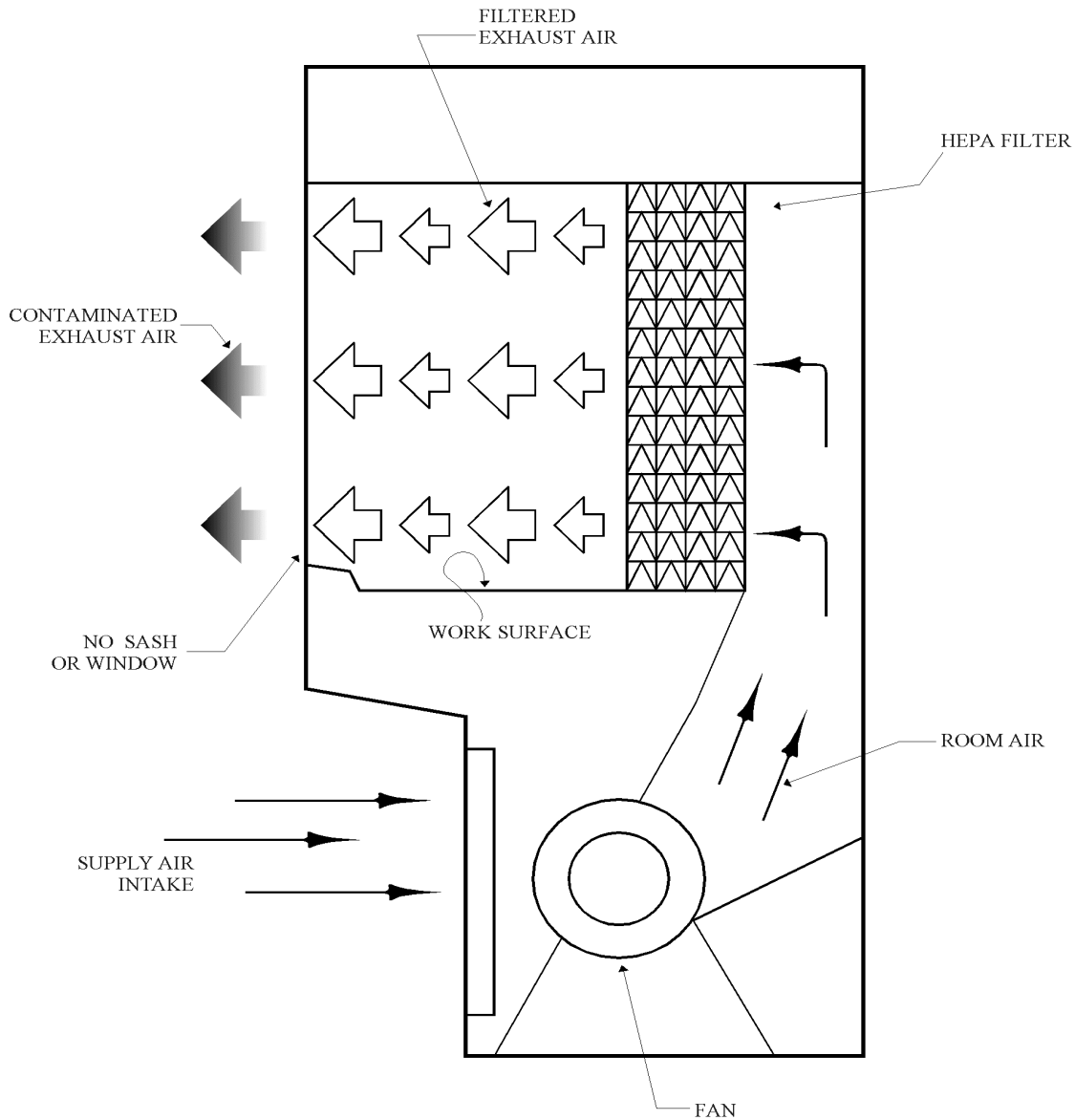

These devices are termed “laminar flow” because they provide a uniform non-mixing air stream through a HEPA filter. They can also be called “clean benches” because they provide a near sterile work area. Since users will be directly exposed to non-purified air during operation, **these hoods must not be used with toxic, allergenic, or infectious materials**. Laminar flow hoods are designed to protect the product or sample from contamination, not the operator.



G-11 Snorkels

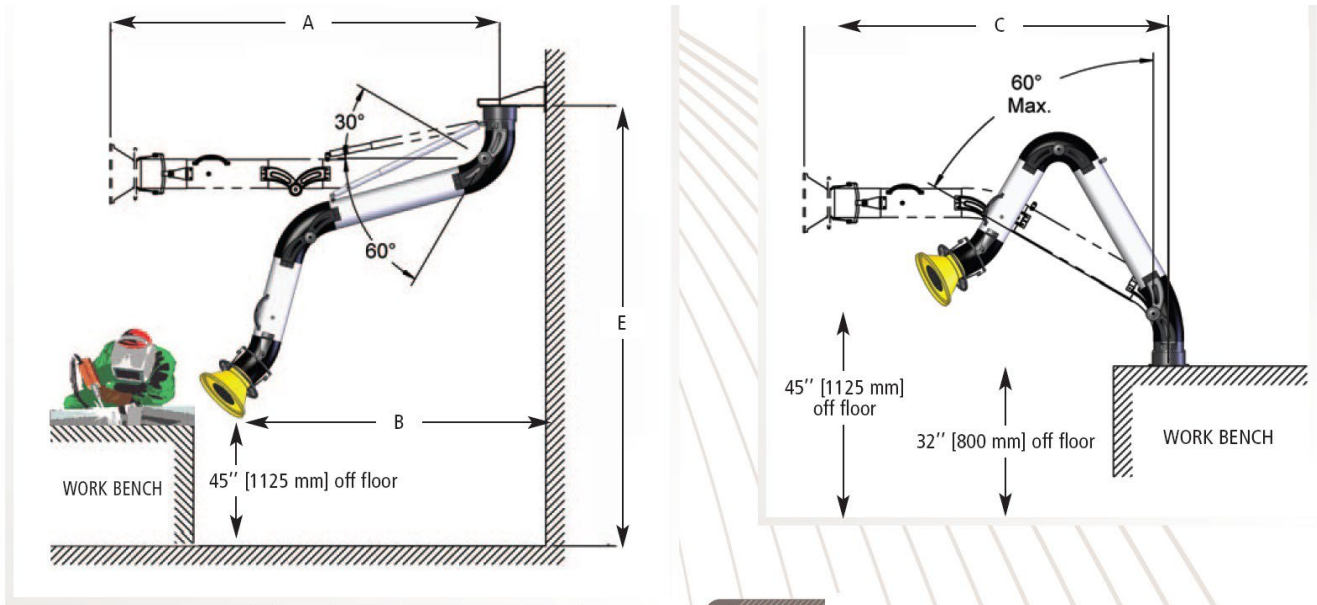
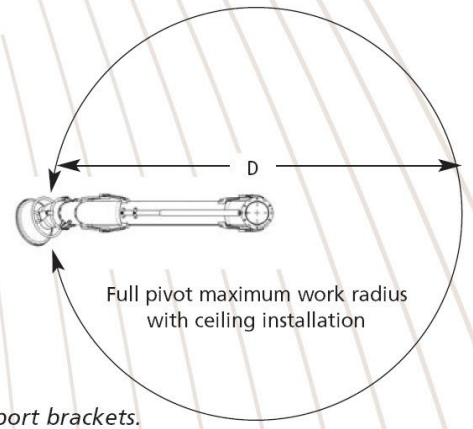

CHART 9

A Arm length [feet] / [m]	B Maximum reach at 45° off floor [feet] / [m]	C Maximum reach at 60° off floor [feet] / [m]	D Maximum reach at 60° off floor [feet] / [m]	E Recommended mounting height [feet] / [m]
3 / 0.9	2.6 / 0.7	3 / 0.9	5.2 / 1.4	6 / 1.5
5 / 1.5	3.5 / 1.1	5 / 1.5	7 / 2.2	6 / 1.5
7 / 2.1	5.5 / 1.7	7 / 2.1	11 / 3.4	6 / 1.5
8.5 / 2.6	7.4 / 2.2	7 / 2.6	14.8 / 4.4	8 / 2.4
10 / 3	8.5 / 2.6	7.8 / 2.4	17 / 5.2	8 / 2.4
14 / 4	11.2 / 3.4	10.2 / 3.2	22.4 / 6.8	8 / 2.4



Note on 14' (4 meters) long arms: reaches indicated in chart 9 are with WBF support brackets.

Standard snorkel tubes are usually made of steel with external cast aluminum joints, which may include adjustable friction discs. The arms typically have a handle attached to the hood to facilitate positioning. Aluminum hood diameters can vary from a few inches to more than a foot in diameter. Hood diverters, which increase capture velocity, might also be installed on some models. The effective capture radius for snorkels is generally equal to one hood diameter from the edge of the hood, with efficiency falling rapidly as distance from the hood increases.

This type of local exhaust device is only appropriate for use with low-hazard materials and is not an adequate substitute for higher-efficiency control devices that must be used when working with moderate- to high-hazard materials.



G-12 Local Exhaust Enclosures

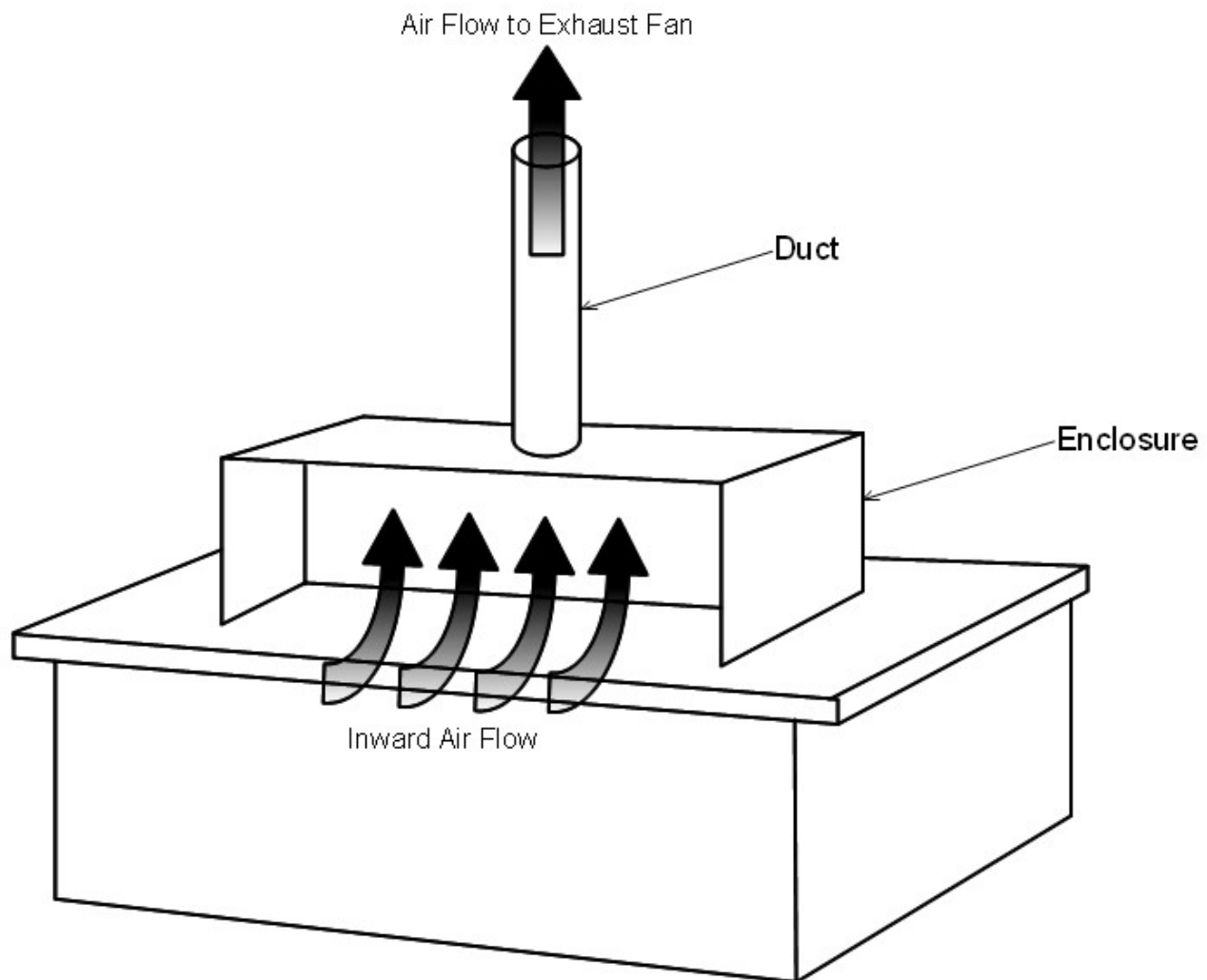

Local Exhaust Enclosure

These enclosures can be found primarily in chemistry laboratories. They are custom made and of metal construction. They have one central pickup area in the center of the enclosure that corresponds to the location where the ductwork penetrates the enclosure box. The efficiency of these control devices drops off rapidly as distance from the pickup area increases. Capture efficiency outside the enclosure is negligible.

The efficiency of these local exhaust enclosures can be adversely affected by small changes in air flow in the local area where installed. **As in the case of snorkels, these local exhaust enclosures are only appropriate for use with low-hazard materials and are not an adequate substitute for higher-efficiency control devices that must be used when working with moderate- to high-hazard materials.**



Appendix H: Overpacking Decision Tree

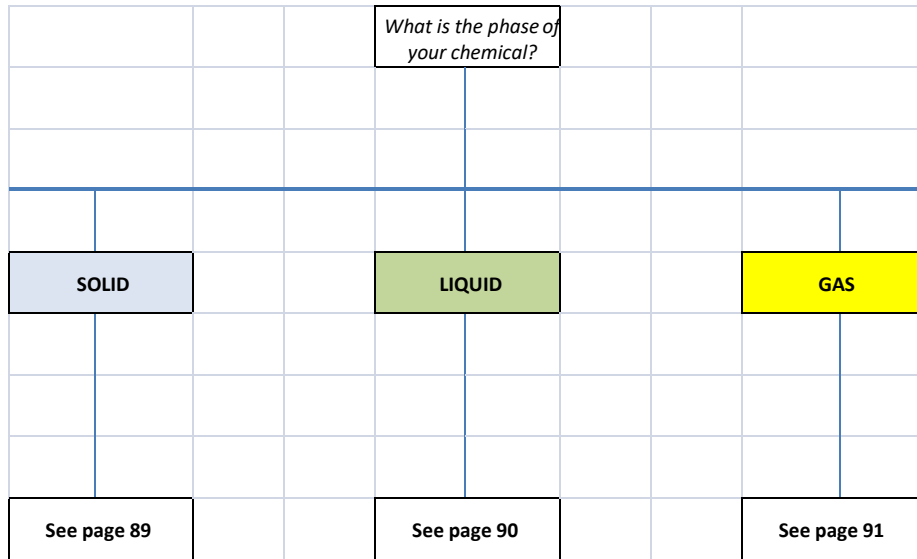

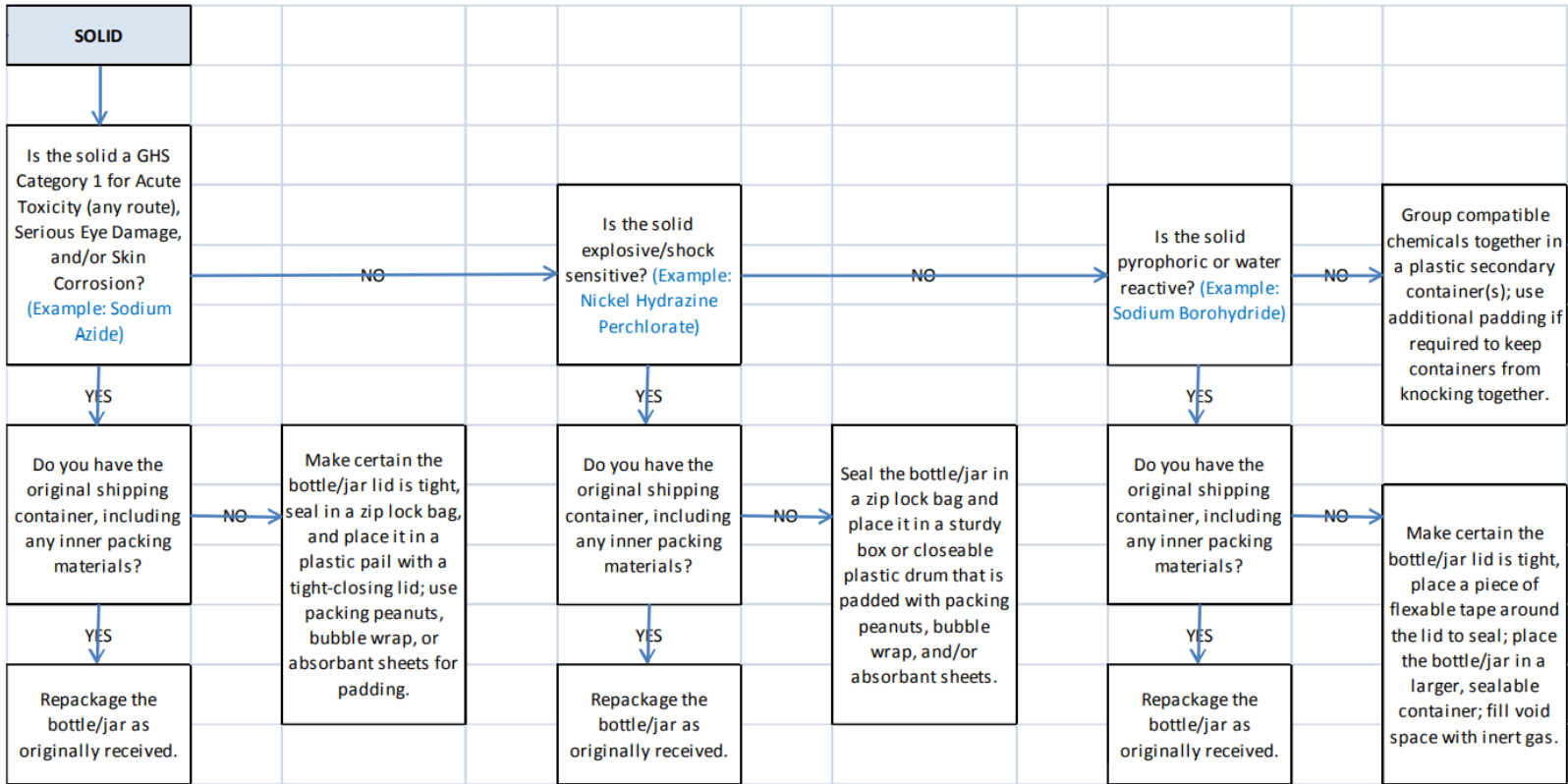

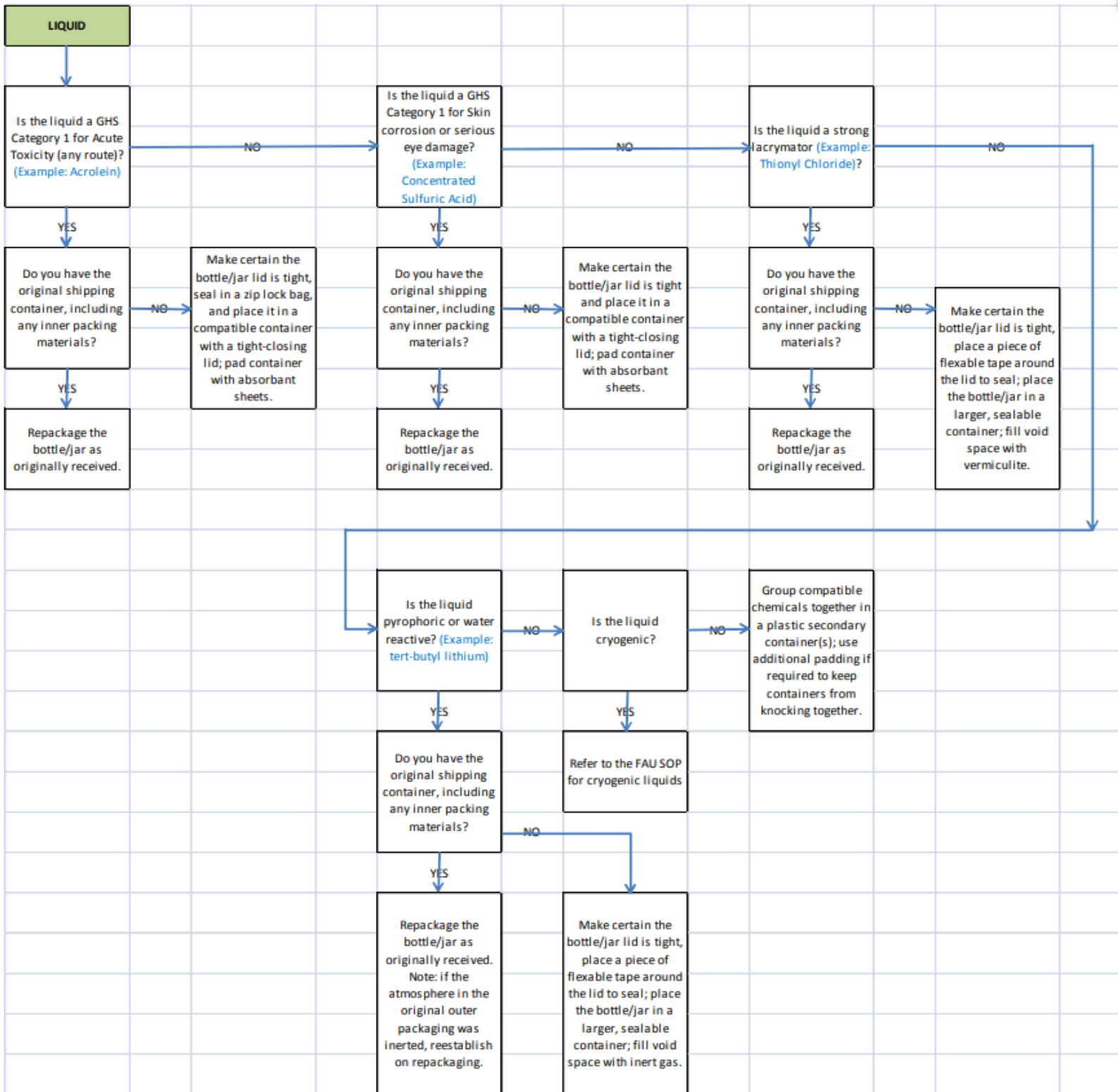

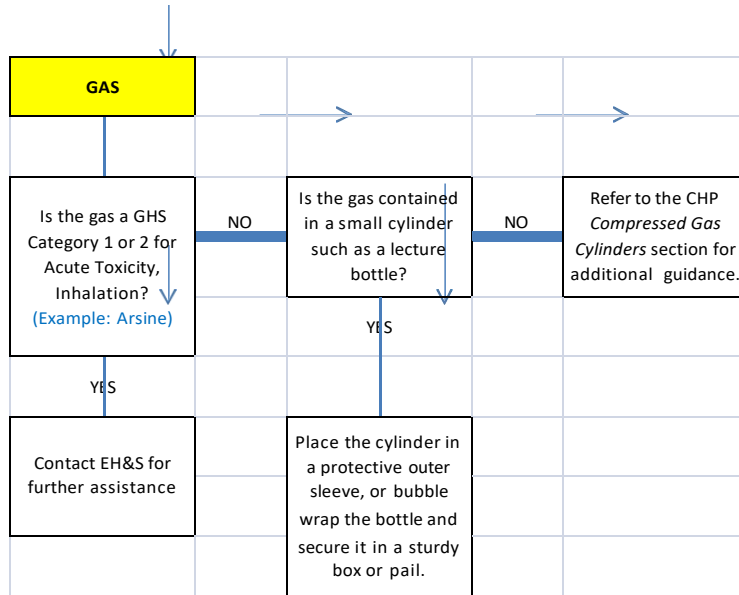



Appendix I: Minors in Research Laboratories or Animal Facilities

Purpose:

Lamar University has a policy regarding children in the workplace (*Human Resources Policy 2.2- AGE LIMITATIONS*). In keeping with LU's mission of student success and leading-edge scholarly activities, persons under the age of 18 might occasionally enter LU research or animal facilities for educational purposes.

The purpose of this appendix is to identify under what circumstances and/or conditions minors will be allowed to visit, work or conduct research in research laboratories where hazardous materials are used or hazardous procedures are conducted, including animal facilities. These guidelines are necessary to help protect a minor's health and safety and to provide reasonable measures to prevent harm arising from potential exposure to hazardous agents or conditions.

Definitions:

Minor – any person who has not attained the age of 18 years.

Laboratories – rooms in which hazardous chemicals, radiation, or biological materials are handled or stored.

Principal Investigator/Sponsor – the person who is responsible for the research project or activity as well as the oversight of the participants in the research or activity, including any minors.

Supervision – management by overseeing the performance or operation of the person or group at all times in the laboratory or animal facility.

Volunteer – any person who provides services to LU with no monetary or material compensation.

Scope:

This appendix covers all Lamar University research laboratories where hazardous materials are used or hazardous procedures are conducted, animal facilities, animal procedures rooms, and animal housing areas.

This appendix encompasses all persons under 18 years of age whether students, employees, or volunteers.

Rules:

1. Minors who participated in a previously approved official Lamar University program are not allowed in LU research facilities for any reason unless they have current approval. Approvals are based on specific projects and time frames of projects.
2. Minors are allowed to work or conduct research in laboratories (except as prohibited in #3 below) if the following requirements are fully met:
 - a. The minor is supervised by the Principal Investigator at all times while in the laboratory and never



left alone.

- b. The EHS & Risk Management appendix, Minors in Research Laboratories or Animal Facilities, has been read and understood. The Potential Hazards Information & Signature Sheet and Waiver of Liability have been reviewed and signed by the parent/legal guardian and returned to EHS & Risk Management, riskmanagement_ehs@lamar.edu.
 - c. The Principal Investigator completes the Minors Research Proposal Registration Form and submits it to EHS & Risk Management two weeks before the minor(s) begins work in the laboratory.
 - d. General laboratory safety training is conducted and documented by EHS & Risk Management. Hazard specific safety training is completed and documented by the Principal Investigator.
 - e. Personal protective equipment, specific to the hazard, is provided to the minor with instructions for use and disposal. At a minimum, and without exception, minors must wear safety glasses, lab coat, long pants/slacks, and closed toed shoes at times while in a laboratory. Gloves must be worn when handling hazardous materials.
 - f. The laboratory is in full compliance with all applicable LU safety programs and regulations.
3. All minors are prohibited from working with the following:
- a. Recombinant or infectious agents designated as BSL-3, ABSL-3 or higher.
 - b. Select agents, controlled substances, or explosives.
 - c. Radioactive materials or radiation (x-rays, gamma, etc.) or lasers.
 - d. Acute Toxins (i.e., mammalian LD50 of less than or equal to ug/kg body weight).
 - e. Animal work that involves any of the above materials or equipment.

Enforcement:

As with other regulations affecting the use of hazardous materials, enforcement of this appendix is the responsibility of the Principal Investigator.



**Parent/Legal Guardian Informed Consent and
Permission to Work in Lamar University Laboratories
(Required for individuals under the age of eighteen)**

Lamar University conducts cutting edge scientific research and is dedicated to providing a healthy and safe environment for its faculty, staff, students, and visitors – including minors participating in LU programs. However, scientific research involves exposure to various hazards. When deciding to allow your child to participate in research projects conducted in LU laboratories and animal facilities, you need to be aware of the potential hazards your child may encounter. The following information provides the most potential hazards, but is not intended to be an inclusive list of all potential hazards.

Definitions

Allergens – substances capable of producing an allergic reaction.

Carcinogens – substances capable of producing cancer.

Pathogens – bacteria, viruses, Prions, fungi, parasites capable of causing diseases.

Recombinant materials – DNA that has been genetically engineered (altered), usually incorporating DNA from more than one species of organism.

Transgenic – an organism that has had genes from another organism inserted into its genes.

Toxins – poisonous substances produced by living organisms, plants and animals.

Zoonotic diseases – diseases that can be passed from animals to humans.

Potential Hazards

Your child's research project may involve one or more of the following potential hazards. A table is attached with examples. You can contact the Principal Investigator to obtain further information on specific hazards that may be used or encountered in the research laboratory.

Animals – can bite, scratch, and transmit zoonotic diseases, such as rabies, toxoplasmosis, pox virus, cat bite fever, rat bite fever, and various parasitic infections or release allergens.

Chemicals – can be unstable, making them reactive and prone to explosion. Potential injuries include skin and eye burns, respiratory problems, allergic reactions, skin, eye, and mucous membrane irritation, and illnesses.

Gas cylinders/compressed gasses – gas cylinders with compressed gasses can explode, causing injury from high speed projectiles. Released gasses can cause eye and skin irritations, respiratory problems, light-headedness, asphyxiation and fainting.

Lasers – device that emits light (electromagnetic radiation) and can cause eye and skin damage.

Pathogens – found in human, animal and plant tissue can cause infections and acute or chronic illnesses.



Mechanical/electrical equipment and instrumentation – can cause electrocution, burns, cuts, scrapes and injuries from pinch points. High noise levels can cause hearing loss.

Radiation/irradiation – can cause skin and eye damage, cellular damage and long-term health problems.

Recombinant materials/technology – can interact with the human body and its cells and produce potentially hazardous results.



**RELEASE OF LIABILITY, WAIVER OF CLAIMS, EXPRESS
ASSUMPTION OF RISKS, AND HOLD HARMLESS AGREEMENT**

I HAVE READ, UNDERSTAND, and INITIALED the Laboratory Rules and Potential Hazard Information Sheet describing the potential risks and dangers associated with my child’s research project. I fully understand that there are potential risks and hazards associated with exposure to hazardous materials or substances.

I AGREE TO ALLOW my minor child to work in LU laboratories and freely accept and assume all associated risks and hazards. I ALSO AGREE AND UNDERSTAND that my child’s research project may be suspended at any time, at the discretion of Lamar University and its officers, agents, and employees, if the safety of my child, LU employees and/or other volunteers at LU become a concern.

I, for myself and my estate, heirs, administrators, executors, and assigns, hereby release and hold harmless the State of Texas, the Texas State University System Board of Trustees, and their officers, directors, employees, representatives, agents, and volunteers (collectively, the “Releases”), from any and all liability and responsibility whatsoever, however caused, for any and all damages, claims, or causes of action that I, my estate, heirs, administrators, executors, or assigns may have for any loss, illness, personal injury, death, or property damage arising out of, connected with, or in any manner pertaining to my child’s work in LU laboratories, whether caused by the negligence of Releases or otherwise. I further hereby agree to defend, indemnify and hold harmless the Releases from any judgment, settlement, loss, liability, damage, or costs, including court costs and attorney fees that Releases may incur.

In signing this agreement, I acknowledge and represent that I have read and understand it and that I sign it voluntarily and for full and adequate consideration, fully intending to be bound by the same.

Printed Name of Minor Child

Signature of Parent/Legal Guardian

Printed Name of Parent/Legal Guardian

Date

I have read, understand, and will adhere to the EHS & Risk Management “Minors in Research Laboratories or Animal Facilities” appendix. I understand that failure to comply with this Policy is dangerous to my health and safety and that I may be removed from the facility immediately for any failures or deviations in compliance.

Signature of Minor

Date



Potential Hazard Information Sheet

Definition	Hazards		Examples
<p>Chemicals</p>	<p>Refined compound that could be in the form of a solid, liquid or gas. These may or may not be hazardous. Some compounds may have numerous hazard classifications (flammable, toxin & carcinogen)</p>	<p>Carcinogens: may cause some sort of cancer with long term exposure - usually many years in the future</p>	<p>Benzene</p>
		<p>Teratogen: shown to affect the reproductive system of males & females & may cause birth defects in the developing fetus.</p>	<p>Alcohol, thalidomide, X-rays</p>
		<p>Neurotoxins: may affect the nervous system.</p>	<p>Ethidium Bromide, snake venom</p>
		<p>Flammables: will burn or explode</p>	<p>Acetone, Xylene, Alcohol</p>
		<p>Reactives: will react explosively</p>	<p>Peroxides, acrylamide</p>
		<p>Corrosives: will cause tissue damage with contact through inhalation, eye, skin, etc</p>	<p>Acids & bases</p>
		<p>Toxins: may cause illness or death on exposure.</p>	<p>Cyanide</p>
<p>Compressed Gases</p>	<p>High-pressure cylinders that hold gases. These are usually large & heavy. Gas may be harmless, toxic, corrosive, flammable</p>	<p>Physical hazard: Explosion hazard if they rupture Asphyxiant hazard if they vent the gas to the workplace & it displaces oxygen</p>	<p>Asphyxiant: Nitrogen, helium, any other non- oxygen gas Flammable: Hydrogen Toxic: Ammonia</p>
<p>Radiation/Radioactive Materials</p>	<p>High energy particles (alpha & beta) or photon (X-rays, gamma)</p>	<p>Tissue & Organ damage with high doses</p>	<p>Uranium, Phosphorus-32, Sulfur-35, X-rays</p>
<p>Physical hazards</p>	<p>Hazards from noise, machinery, heat, cold, etc.</p>	<p>Tissue damage, hearing loss</p>	<p>Scrapes, cuts Cold: liquid nitrogen, dry ice Heat: burners</p>



Lasers	Light Amplification by Stimulated Emission of Radiation	Eye damage and possible skin damage	Class IIIB and IV, and open beam laser operation
---------------	---	-------------------------------------	--

P/LG Initials: _____ Date: _____



Potential Hazard Information Sheet

Definition	Hazards	Examples	
Biological Agents	Living organisms or products of living organisms such as Viruses, Bacteria, Fungi, Prions & Parasites. Hazards from infection with these agents are organism dependent & can range from mild treatable to severe untreatable. Classification of hazard in four groups called biological safety levels with level 1 as the least hazard & level 4 as the	Level 1 - No hazard	Baker's Yeast & E. coli K12
		Level 2 - Mild to severe illness	Influenza, Polio & Salmonella
		Level 3 – Severe illness & possible death	Tuberculosis & AIDS
		Level 4 – Not allowed at LU	Hemorrhagic fever
Recombinant DNA	Genetically modified organisms with variations in genes within the organism.	Often unknown consequences once introduced to the human body.	Viral vectors like Adeno & Adeno-associated viruses used to transfect or express genes.
Toxins – Microbial, Plant, Animal	Poisons produced by plants, living organisms or animals.	Tissue & organ damage or death.	Plant – Ricin Animal – Fish & Snake venom Microbial – Staph, Tetanus

P/LG Initials: _____ Date: _____



Rules for Minors Working in Laboratories and Animal Facilities

1. Never work alone in any laboratory environment without direct, immediate adult supervision from the Principal Investigator.
2. Always wear the personal protective equipment as directed and dispose of it appropriately. This personal protective equipment (PPE) includes goggles, gloves, coats/gowns, and other face/body protection as determined by the hazard being worked with or around. Always remove PPE when leaving the work area.
3. Always follow the instructions of the Principal Investigator.
4. Always report any accident (regardless of severity) immediately to the Principal Investigator.
5. Always keep hands away from face and wash them well with soap and water prior to leaving any laboratory area and after removing gloves.
6. Never eat, drink, chew gum, apply lip balm, or touch contact lenses while in any laboratory environment.
7. Always wear closed-toe shoes while in any laboratory.
8. Always tie back long hair to keep it out of all the hazards listed above.
9. Always wear clothing that reduces the amount of exposed skin.
10. Always ask questions if unsure of any safety requirement.

P/LG Initials: _____ Date: _____



Minors Research Proposal Registration Form

(Please print, type or fill this form out on the computer)

EHS & Risk Management Use Only Minors Research Proposal # M

Proposals are due at the EH&S Office at least 2 weeks prior to beginning the work.

Principal Investigator/Sponsor: _____

Department: _____

Phone: _____

Email: _____

Student/Minor Name: _____

Date of birth: _____

School: _____

Is this project (check one)

Student Intern

Volunteering

Employment

Other (specify) _____

Part of a Lamar University University Sponsored Program (which program?) _____

Other (explain) _____

This work will be performed in: BLDG _____, Room(s) _____

Project Title: _____

Project Start Date: _____

Project End Date: _____



Materials and Equipment to be Used - Check and List all that apply:

Chemicals

- Flammable
- Reactive
- Carcinogenic
- Toxic
- Corrosive
- Oxidizer
- Cryogen
- Pharmaceuticals
- Gases

Biological Material

- Recombinant DNA
- Bacteria
- Viruses
- Fungi
- Parasites
- Human Source Material
- Insects
- Plants
- Animals

Equipment

- Fume Hood
- Biosafety Cabinet
- Laminar Clean Bench
- Autoclave
- Centrifuge
- Analytical Instruments
- Industrial Machinery
- Noise Producing Equip.
- Other Equipment



Project Description (attach separate sheet if necessary):

I AGREE TO SPONSOR (MINOR'S NAME) _____, AND BY MY SIGNATURE BELOW, AGREE THAT:

- I have read, understand, and will adhere to the LU "Minors in Research Laboratories or Animal Facilities" Appendix. The potential hazard information signature sheet is attached.
- I have completed this Minor's Hazard Specific Safety Training. Training was conducted by doing the following:

- Personal protective equipment appropriate for, and specific to, laboratory hazards will be provided.
- This individual will be supervised at all times while in the laboratory and never left alone.
- My laboratory is in full compliance with all applicable Lamar University safety programs and regulations.

Printed Name of PI/Sponsor

Signature of PI/Sponsor

Date



Institutional Biosafety Committee (IBC) Approval (*if required*)

Initials

Date

Institutional Animal Care and Use Committee (IACUC) Approval (*if required*)

Initials

Date

EHS & Risk Management Approval

Initials

Date

**Please scan and return this form
to riskmanagement_ehs@lamar.edu**

Appendix J: Storing Chemicals Safely

Rules for Safely Storing Chemicals

1. Store like chemicals together and away from incompatible groups of chemicals. Do not store chemicals in alphabetical order, except within compatible hazard groupings. An easy way to store chemicals properly may be to use the chemical manufacturer's color-coding system, if the manufacturer uses such a system to indicate hazards. (i.e. store reds with reds, blues with blues, etc.) Contact EHS & Risk Management at (409) 880-8276 for assistance, if needed.
2. Flammable materials should be stored in an approved, dedicated, flammable materials storage cabinet or room if the volume exceeds ten (10) gallons.
3. Liquids should be stored in unbreakable or double-contained packaging, or the storage cabinet should have the capacity to hold the contents if the container breaks.
4. Avoid floor chemical storage (even temporary).
5. Chemicals should be stored no higher than eye level and never on the top shelf of a storage unit.
6. Shelf assemblies should be firmly secured to the walls. Avoid island shelves.
7. Each shelf should have an anti-roll lip.
8. Store acids in a dedicated acid cabinet. Nitric acid may be stored there also, if it is kept isolated from the others and away from Acetic Acid or other organic acids.
9. Store severe poisons in a dedicated poison cabinet.
10. All chemicals should be labeled and dated.
11. Look for unusual conditions in chemical storage areas, such as:
 - improper storage of chemicals
 - leaking or deteriorating containers



- spilled chemicals
- temperature extremes (too hot or cold in storage area)
- lack of or low lighting levels
- blocked exits or aisles
- doors blocked open, lack of security
- trash accumulation, smoking, or open lights or matches
- fire equipment blocked, broken or missing
- lack of information or warning signs ("No Smoking", "Flammable Liquids", "Acids", "Corrosives", "Poisons", Chemical Storage")

Any of these conditions should be corrected immediately. Routine inspections of chemical storage areas will prevent accidents.

Suggested Storage Limits For Common Peroxidizable Compounds

Class A - HIGHLY HAZARDOUS: Discard on or before 3 months.

Peroxide formation hazard during storage.

isopropyl ether	divinyl acetylene
vinylidene chloride	potassium metal
sodium amide	potassium amide

Class B - HAZARDOUS: Discard or test after 6 months.

Peroxide formation hazard during storage and on concentration (i.e. distillation) of compound

diethyl ether	dicyclopentadiene
tetrahydrofuran	diacetylene
dioxane	methyl acetylene
acetal	cumene
methyl isobutyl ketone	tetrahydronaphthalene
ethylene glycol dimethyl ether	cyclohexene
vinyl ethers	methylcyclopentane

CLASS C – POTENTIALLY HAZARDOUS: Discard or test after one year.

Peroxide formation causes initiation of hazardous polymerization.

methyl methacrylate	chlorotrifluoroethylene
styrene	vinyl acetylene
acrylic acid	vinyl acetate
acrylonitrile	vinyl chloride
butadiene	vinyl pyridine
tetrafluoroethylene	chloroprene

Safety Hints:

1. Do not purchase these compounds in quantities greater than can be used in the specified storage time period.
2. Ethers should be stored in the dark and under argon or nitrogen if possible.
3. Always check for the presence of peroxides before distilling any peroxide former.

4. Consult safety references before working with peroxidizable compounds.

Short List of Incompatible Materials

ALKALI METALS , such as calcium, potassium, and sodium with: water, carbon dioxide, carbon tetrachloride, and other chlorinated hydrocarbons.	ACETIC ACID with: chromic acid, nitric acid, hydroxyl containing compounds, ethylene glycol, perchloric acid, peroxides, and permanganates.
ACETONE with: concentrated sulfuric acid and nitric acid mixtures.	ACETYLENE with: copper (tubing), fluorine, bromine, chlorine, iodine, silver, mercury, or their compounds.
AMMONIA , ANHYDROUS with: mercury, halogens, calcium hypochlorite, or hydrogen fluoride.	AMMONIUM NITRATE with: acids, metal powders, flammable liquids, chlorates, nitrates, sulfur, and finely divided organics or other combustibles.
ANILINE with: nitric acid, hydrogen peroxide, or other strong oxidizing substances.	BROMINE with: ammonia, acetylene, butadiene, butane, hydrogen, sodium carbide, turpentine, or finely divided metals.
CHLORATES with: ammonium salts, acids, metal powders, sulfur, carbon, finely divided organics or other combustibles.	CHROMIC ACID with: acetic acid, naphthalene, camphor, alcohol, glycerin, turpentine, and other flammable liquids.
CHLORINE with: ammonia, acetylene, butadiene, benzene and other petroleum fractions, hydrogen, sodium carbides, turpentine, and finely divided metals.	CYANIDES with: acids.
HYDROGEN PEROXIDE with: copper, chromium, iron, most metals or their respective salts, flammable liquids and other combustible materials, aniline, and nitromethane.	HYDROGEN SULFIDE with: nitric acid, oxidizing gases.
HYDROCARBONS , generally, with: fluorine, chlorine, bromine, chromic acid, or sodium peroxide.	IODINE with: acetylene or ammonia.
MERCURY with: acetylene, fluminic acid, or hydrogen.	NITRIC ACID with: acetic, chromic, or hydrocyanic acids, aniline, carbon, hydrogen sulfide, flammable liquids or gases, or other substances which are readily nitrated.
OXYGEN with: oils greases, hydrogen, flammable liquids, solids, or gases.	OXALIC ACID with: silver or mercury
PERCHLORIC ACID with: acetic anhydride, bismuth and its alloys, alcohol, paper, wood, and other organic materials.	PHOSPHOROUS PENTOXIDE with: water.
POTASSIUM PERMANGANATE with: glycerin, ethylene glycol, benzaldehyde, or sulfuric acid.	SODIUM PEROXIDE with: any oxidizable substances, for instance: methanol, glacial acetic acid, acetic anhydride, benzaldehyde, carbon disulfide, glycerin, ethylene glycol, ethyl acetate, furfural, etc.

SULFURIC ACID with: chlorates, perchlorates, permanganates, and water

NOTE: This list is not a complete list of incompatible materials. It contains some of the more common incompatible materials. Always research the materials you work with in order to be safe.

Shock Sensitive Compounds

Acetylenic compounds – especially polyacetylenes, haloacetylenes and heavy metal salts of acetylenes (copper, silver, and mercury salts are particularly sensitive)

Acyl nitrates

Alkyl nitrates - particularly poly nitrates (i.e. nitrocellulose and nitroglycerine)

Alkyl and acyl nitrites

Alkyl perchlorates

Aminometal oxosalts - metal compounds with coordinated ammonia, hydrazine or similar nitrogenous donors and ionic perchlorate, nitrate, permanganate or other oxidizing groups

Azides - including metal, nonmetal and other organic azides

Chlorite salts or metals (i.e. AgClO_2 and $\text{Hg}(\text{ClO}_2)_2$)

Diazo compounds (i.e. CH_2N_2)

Diazonium salts (when dry)

Fulminates - silver fulminate (AgCNO) can form in the reaction mixture from the Tollen' test for aldehydes if it is allowed to stand for some time; this can be prevented by adding dilute nitric acid to the test mixture as soon as the test has been completed

Hydrogen peroxide - becomes increasingly treacherous as the concentration rises above 30%, forming explosive mixtures with organic materials and decomposing violently in the presence of traces of transition metals

N-Halogen compounds (i.e. difluoroamino compounds and halogen azides)

N-Nitro compounds (i.e. N-nitromethylamine, nitrourea, nitroguanidine and nitricamide)

Oxo salts of nitrogenous bases - perchlorates, dichromates, nitrates, iodates, chlorites, chlorates and permanganates of ammonia, amines, hydroxylamine, guanidine, etc.

Perchlorate salts - most metal, nonmetal and amine perchlorates can be detonated and may undergo violent reaction in contact with combustible materials

Peroxides and hydroperoxides

Peroxides (solid) - crystallized form or are left from evaporation of peroxidizable solvents

Peroxides – transition-metal salts



Picrates - especially salts of transition and heavy metals (i.e. Ni, Pb, Hg, Cu and Zn); picric acid is explosive but less sensitive to shock or friction than its metal salts and is relatively safe as long as wetted and not dried out.

Polynitroalkyl compounds (i.e. tetranitromethane and dinitroacetonitrile)

Polynitroaromatic compounds - especially polynitro hydrocarbons, phenols and amines



Appendix K: Glove Selection Chart

The following guide was developed from information in several sources. Many factors affect the breakthrough times of glove materials, including, but not limited to, the thickness of glove material, concentration of the chemical, amount of chemical with which the glove comes into contact, length of time the glove is exposed to the chemical, the temperature, and abrasion or puncture.*

General Safety Procedures

This information is provided as a guide to proper glove material selection. Glove performance varies between manufacturers, so before working with any highly toxic chemical always consult the manufacturer to make sure that the correct gloves are used for the application. Generally, **Nitrile** is recommended as a good all-purpose glove for non-toxic chemicals. Silver Shield or Lamine Film are the best gloves for more toxic or unknown hazards, BUT, always check with the manufacturer before using with any toxic or unknown substance. When using gloves follow these safety procedures:

- Make sure the glove material is resistant and compatible with the substances in use.
- Inspect gloves for holes and tears before each use.
- Wash gloves appropriately before removing them.
- In order to prevent the unintentional spread of hazardous substances, remove gloves before handling objects such as doorknobs, telephones, pens etc. and before leaving the laboratory.
- Replace gloves periodically, depending on their permeation and degradation characteristics.

Selection Key:

4 = Excellent, breakthrough times generally greater than 8 hours.

3 = Good, breakthrough times generally greater than 4 hours.

2 = Fair, breakthrough times generally greater than 1 hour.

1 = Not Recommended, breakthrough times generally less than 1 hour.

? = Not Tested or No Information, check other references.

* Sources:

ILC Dover Chemical Compatibility Chart.

Glove Resistance Ratings, James North & Sons, Inc. Quick Selection

Guide to Chemical Protective Clothing, 2nd Edition, Forsberg &

Mansdorf.



Glove Selection Guide

Chemical	Natural Rubber	Neoprene	Butyl	PVC	Nitrile	Viton®
Alcohols						
Allyl alcohol	1	1	4	1	4	3
Butyl alcohol	1	3	4	2	3	4
Ethyl alcohol	1	2	4	1	3	4
Isopropyl alcohol	1	3	4	2	4	4
Methyl alcohol	1	1	4	1	1	4
Aldehydes						
Acetaldehyde	1	1	4	1	1	1
Acrolein	1	1	4	1	1	1
Benzaldehyde	1	1	4	1	1	3
Butyraldehyde	1	1	4	1	1	1
Formaldehyde	1	2	4	2	4	4
Glutaraldehyde	?	4	4	2	?	4
Aliphatic Hydrocarbons						
Diesel Fuel	1	2	1	2	3	4
Hexanes	1	1	1	1	4	4
Kerosene	1	3	1	3	4	4



Chemical	Natural Rubber	Neoprene	Butyl	PVC	Nitrile	Viton®
Naphtha	1	2	1	3	4	4
Pentane	1	1	1	1	3	4
Petroleum Ether	1	1	1	2	3	4
Turpentine	1	1	1	1	2	4

Alkalis

Ammonium Hydroxide up to 70%	1	3	4	2	3	?
Potassium Hydroxide up to 70 %	4	4	4	4	4	4
Sodium Hydroxide 70 + %	4	4	4	4	3	3

Amines

Aniline	1	1	1	1	2	1
Ethanolamine	2	4	4	3	4	4
Ethylamine	1	2	4	1	1	1
Methylamine	1	3	4	2	4	4
Triethanolamine	1	1	4	1	4	4

Aromatic Hydrocarbons

Benzene	1	1	1	1	1	3
Gasoline	1	1	1	1	4	4
Naphthalene	1	1	1	1	4	4
Toluene	1	1	1	1	1	4
Xylene	1	1	1	1	1	4



Chemical	Natural Rubber	Neoprene	Butyl	PVC	Nitrile	Viton®
Elements						
Bromine	1	2	1	?	1	4
Chlorine aqueous	?	1	2	?	1	4
Iodine	?	1	3	?	3	4
Mercury	?	4	4	?	4	4
Esters						
Ethyl acetate	1	1	3	1	1	1
Butyl acetate	1	1	2	1	1	1
Methyl acetate	1	1	4	1	1	1
Isobutyl acrylate	1	1	4	1	1	1
Ethers/Glycols						
Diethyl ether	1	2	1	1	2	1
Ethylene glycol	1	2	4	1	2	4
Isopropyl ether	1	2	1	1	3	1
Propylene glycol	?	3	3	2	2	?
Tetrahydrofuran	1	1	2	1	1	1
Halogenated Hydrocarbons						
Carbon Tetrachloride	1	1	1	1	1	4



Chemical	Natural Rubber	Neoprene	Butyl	PVC	Nitrile	Viton®
Chloroform	1	1	1	1	1	4
Methylene Chloride	1	1	1	1	2	3
Polychlorinated Biphenyls(PCB's)	1	4	4	?	2	4
Perchloroethylene	1	1	1	1	2	4
Trichloroethylene	1	1	1	1	1	4

Inorganic Acids

Chromic acid up to 70%	1	1	4	3	3	4
Hydrochloric acid up to 37%	3	3	4	3	3	3
Hydrofluoric acid up to 70%	2	2	3	1	1	?
Nitric acid 70+ %	?	1	2	?	1	4
Perchloric acid up to 70%	4	4	3	4	4	4
Phosphoric acid 70+ %	4	4	4	4	4	4
Sulfuric acid 70+ %	1	2	4	2	1	2

Ketones

Acetone	1	1	4	1	1	1
Diisobutyl ketone	1	1	2	1	1	2
Methyl ethyl ketone	1	1	4	1	1	1

Miscellaneous



Acetic anhydride	1	2	4	1	1	1
Chemical	Natural Rubber	Neoprene	Butyl	PVC	Nitrile	Viton®
Acetonitrile	1	1	4	1	1	1
Acrylamide	1	1	3	1	2	3
Carbon disulfide	1	1	1	1	1	4
Cresols	1	3	4	?	2	4
Cutting fluid	?	2	?	2	3	?
Dimethyl sulfoxide	1	4	4	1	1	1
Hydraulic oil	?	?	1	2	3	?
Hydrazine	2	4	4	4	4	1
Hydrogen Peroxide	4	2	4	3	4	4
Lubricating oil	3	3	?	?	4	3
Malathion	?	3	1	?	3	?
Nitrobenzene	1	1	4	1	1	4
Phenol	1	3	2	1	1	4
Photo solutions	3	4	?	3	4	?
Picric acid	1	2	3	1	2	4



Pyridine	1	1	4	1	1	1
----------	---	---	---	---	---	---

Organic Acids

Chemical	Natural Rubber	Neoprene	Butyl	PVC	Nitrile	Viton®
Acetic acid	2	3	4	2	1	4
Formic acid	2	3	4	3	2	2
Lactic Acid	4	4	4	3	4	4
Maleic acid	3	3	2	3	3	4
Oxalic Acid	4	4	4	4	4	4

Salt Solutions

Ammonium nitrate	4	4	4	4	4	4
Calcium hypochlorite	1	3	4	4	3	4
Ferric chloride	4	4	4	4	4	4
Mercuric chloride	3	3	4	3	3	4
Potassium cyanide	4	4	4	4	4	4
Potassium dichromate	4	4	4	4	4	4
Potassium permanganate	4	4	?	4	4	?
Sodium cyanide	4	4	4	4	4	4
Sodium thiosulfate	4	4	4	4	4	4

Appendix L: Lab Inspection Manual

I. PURPOSE AND SCOPE

Lamar University is responsible for providing to each of our employees, employment, and a place of employment which are “free from recognized hazards that are causing or likely to cause death or serious injury to” our employees, as outlined in Occupational Safety and Health Act, Section 5(a)(1). The purpose of this document is to outline a method for preventing such hazards from developing, by providing regular inspections of laboratory working conditions.

II. POLICY STATEMENT

- A. Lamar University has established and utilizes a Laboratory Inspection Policy.
- B. This policy is to be used at any time that the Building and Laboratory Safety Coordinator inspects the condition of a laboratory within Lamar University, under the control of a professor, an academic department, the chair of a department, or any other functional group within or beyond Lamar University.
- C. Individual departments, buildings and units will explain the laboratory inspection policy to all prior and new laboratory controllers. All departments, buildings, and units responsible for laboratories must accept at least one regular inspection each year, but all departments, buildings, and units responsible for laboratories may request further inspection as well, if they choose to do so.

III. DEFINITIONS

- A. Laboratory Controller (LC): The individual or group controlling a laboratory within Lamar University. This may be someone carrying out research within the laboratory, or an individual who has accepted responsibility over the lab until someone who would use it is found, such as a departmental chair.
- B. Laboratory- Any facility within Lamar University where substantial chemical or physical hazards are observed, which is used for learning, and/or research. This can range from an art studio to an industrial pilot plant.
- C. Lab- A term considered synonymous with this Appendix’s definition of Laboratory.
- D. Lamar University Building and Laboratory Safety Coordinator (Coordinator) - An employee of the Environmental Health and Safety and Risk Management department, tasked with carrying out the overall laboratory inspection program.
- E. Director of the Office of Environmental Health and Risk Management (Director)- The direct superior of the Lamar University Building and Laboratory Safety Coordinator.
- F. Departmental Chair (Chair) - Individual overseeing an academic department, Center, or other entity. This entity possesses jurisdiction over the Lab Controller’s laboratory. The Departmental Chair is expected to manage any Institutional Concerns.



- G. Department- Any group or facility under the control of a Departmental Chair. A department does not have to be an academic department.

IV. LU LABORATORY INSPECTION RESPONSIBILITIES

A. Lamar University Building and Laboratory Safety Coordinator (Coordinator) Responsibilities:

1. Coordinator shall design a Laboratory Inspection Form and provide it to LCs and Departmental Chairs upon request.
 - a. Director of Environmental Health and Safety and Risk Management shall post the Laboratory Inspection Form to the web page of the Office of Environmental Health and Safety and Risk Management.
 - b. Laboratory Inspection Form will be considered official upon approval by Vice President for Administration and Finance.
2. Coordinator shall review this policy, and the Form, yearly, and update them as necessary.
 - a. The updates to this policy, and the Form, will be considered binding upon approval by Vice President for Administration and Finance.
 - b. After receiving approval, Building and Laboratory Safety Coordinator shall send the new policy and form, highlighting any changes, to all Departmental Chairs responsible for any laboratories, and to the Director, if the Director has not already received such notice.
 - c. Upon the approval of any updates to the Form, the Director shall post the updated Laboratory Inspection Form to the web page of the Office of Environmental Health and Safety and Risk Management (see below).
3. Coordinator shall routinely investigate each lab every year, using the Laboratory Inspection Form, and report the findings of each lab's investigation to Lab Controller, and the Departmental Chair.
 - a. Prior to routine inspection, Coordinator shall give at least three business days' notice to the Lab Controller(s) to be inspected.
 - b. Coordinator shall make a reasonable effort, as determined by the Director, to accommodate the schedules of Lab Controllers during routine inspections.
4. Coordinator shall investigate any lab subject to serious complaint and shall investigate any lab where clear life safety hazards are observed, as soon as possible. Coordinator shall instruct cessation of activities, if and only if a clear and present danger to life safety is apparent. At time of activity cessation/work stoppage, Coordinator shall indicate how the decision can be appealed to the Director.
5. Coordinator shall note any safety concerns encountered in investigations of labs within a department that can be solved most readily at the departmental level, and shall include them in the report.
6. After the due dates for Action Items recommended by the Coordinator's inspection of a given lab or department, the Coordinator shall carry out a follow-up inspection, to evaluate compliance.



- a. Prior to follow-up, Coordinator shall give at least three business days' notice to the Lab Controller(s) to be inspected.
- b. Coordinator shall make a reasonable effort, as determined by the Director of the Office of Environmental Health and Safety and Risk Management, to accommodate the schedules of Lab Controllers whose compliance is being followed up on.
- c. If, in the judgement of the Coordinator, all concerns have been addressed, then the Coordinator shall inform the department and the Director via written report.
- d. If, in the judgement of the Coordinator, the lab or department has made a good faith effort to address the concerns raised, despite not addressing all concerns, then, with the Director's approval, the Coordinator shall give them a written update, and reminder of what concerns remain, before setting a later date for a further follow-up.
- e. If, in the judgement of the Coordinator, the lab or department has not made a good faith effort to address the concerns raised, then the Coordinator shall send notice of this noncompliance to the applicable lab or department, and shall note the potential consequences of this noncompliance, as well as information that would allow the lab or department to appeal the decision of the Coordinator to the Director.
- f. If a lab or department successfully appeals the determination of noncompliance, then the Coordinator shall treat the outcome as though all concerns were addressed, or as though a good faith effort was made to address the concerns raised, at the Director's discretion.

B. Manager of Campus Safety Responsibilities

1. The Manager shall post the most recent version of the Laboratory Inspection Form to the website for the Office of Environmental Health and Safety and Risk Management.
2. The Manager shall consider any determination by the Coordinator that a lab or department found to be out of compliance is making a good faith effort to address the concerns raised.
3. The Manager shall consider any appeals of the Coordinator's work stoppage order.
4. The Manager shall consider any appeals of the Coordinator's determinations of noncompliance, giving both the appealing lab or department and the Coordinator a chance to explain their reasoning.

C. Laboratory Controller (LC) Responsibilities:

1. The LC is advised, but not required, to keep a copy of the Laboratory Inspection Form in the lab, to help keep some of the safety concerns within at the top of the minds of those operating within the lab.
2. LC shall address all concerns brought up by the Building and Laboratory Safety Coordinator's yearly safety inspection, prior to the due date(s) presented in the lab inspection report.

D. Departmental Chair (Chair) Responsibilities:



1. Departmental Chair shall arrange for Action Items brought up by the lab inspection report to be addressed prior to the Action Items' due date, if said Action Items are most readily addressed at the departmental level.

Appendix M: Hazardous Materials Manual

Purpose

The purpose of this policy is to provide University faculty, staff, and students with guidance in the safe and proper storage, handling and disposal of Hazardous Materials. While this document does not cover all regulatory requirements concerning the handling, storage and disposal of hazardous materials, it provides the basic information necessary for most laboratories to comply with applicable regulations. Additional information is available through EHS & Risk Management.

Definition of Hazardous Materials

A hazardous material is a substance, which is capable of producing harmful physical or health effects. Harmful physical effects include: fire, sudden release of pressure, explosion, and other violent reactions. Harmful health effects include: acute conditions and chronic conditions. Acute conditions develop soon after an over-exposure to hazardous materials and include: burns, rashes, respiratory distress, convulsions, and possibly even death. Chronic conditions develop after long term exposure to hazardous materials and include; cancers, nervous system disorders, and damage to other organ systems.

Classification of Hazardous Materials

In order to safely handle and store hazardous materials, it is important to know the hazards. The hazards of most materials fall into one or more of the following classifications:

Flammable Liquid

Generally, any liquid that produces enough vapor at a temperature less than or equal to 140 °F (60.0 °C) to ignite when exposed to an ignition source. In the United States, the legal definition of a flammable liquid has different meanings from agency-to-agency as follows:

- DOT defines a flammable liquid as any liquid having a flash point of not more than 141 °F (60.6 °C), or any material in a liquid phase with a flash point at or above 100 °F (37.8 °C) that is intentionally heated and offered for transportation.
- OSHA defines a flammable liquid as any liquid having a flashpoint below 100 °F (37.8 °C), except any mixture having components with flashpoints of 100 °F (37.8 °C) or higher, the total of which make up 99 percent or more of the total volume of the mixture.
- EPA uses the term “ignitable” rather than flammable, and defines it as a liquid, other than an aqueous solution containing less than 24 percent alcohol by volume, and has flash point less than 140 °F (60 °C),

Note that a chemical might not be labeled as flammable under the auspices of OSHA; however, it may still



meet the definition of flammable or ignitable as defined by DOT and EPA, respectively.

Combustible Liquid

Any liquid which has a flash point between 141 °F (60.5 °C) and 200°F (93.3°C).

Flammable Solid

A substance that can cause a fire through friction, absorption of moisture or spontaneous chemical changes and, when ignited, will burn so vigorously that it creates a hazard e.g. sodium borohydride, coal, etc.

Oxidizer

A substance that readily yields oxygen or another electron acceptor to stimulate the combustion of organic matter (fuel) e.g. nitrates, permanganates, etc.

Corrosive

A liquid that corrodes steel (SAE 1020) at a rate greater than 6.35 mm (0.250 in.) per year at a test temperature of 130°F (55°C) or has a pH less than 2 or greater than 12.5 e.g. acids, bases, anhydrides, etc.

Organic Peroxide

An organic compound containing the chemical bond -O-O- (oxygen joined to oxygen).

Poison

A substance so toxic that it presents a risk to life or health.

Explosive

Any chemical compound, mixture or device that reacts or decomposes with substantial instantaneous release of gas and heat.

Compressed Gas

A substance in gas or liquid form contained in a vessel under pressure. This includes cylinders, lecture bottles, and aerosol cans. These substances may be flammable, non-flammable, or poisonous.

Cryogenics

Substances which are extremely cold such as liquid nitrogen, liquid helium and dry ice. These substances can displace air and may become asphyxiation hazards if spilled in non-ventilated areas.

Radioactive

Any material that contains atoms which are unstable and attempt to become more stable by ejecting alpha particles, beta particles, gamma rays, x-rays, neutrons, high-speed electrons, high-speed protons, and other particles capable of producing ions. Examples of radioactive waste materials include:

- (1) solid waste; such as, contaminated PPE and glassware, scintillation vials, plastic ware, paper, gels, animal carcasses, and plant tissue –and-
- (2) liquid waste; such as, scintillation cocktails, electrophoresis gels, and discarded stock radioisotopes.



See the LU [Radiation Safety Manual](#) for specific information on the generation and proper disposal of radioactive material.

Potentially Infectious Materials

Tissues, organs, and blood from humans and primates. Syringes, needles, sharps, and other objects containing materials above.

Hazardous Materials Training Requirements

Laboratory personnel working with any of the mentioned hazardous materials must receive Laboratory Safety Training, as part of orientation, and annually thereafter. EHS & Risk Management provides general Laboratory Safety Training. The Principal Investigator or Lab Manager is responsible for training other lab personnel about specific hazards and Standard Operating Procedures in their areas. Federal and State regulations may require other training, such as Hazard Communication, Hazardous Waste Disposal and Bloodborne Pathogens. These are offered by EHS & Risk Management. Radiation Safety training is available from the Radiation Safety Officer.

Storage and Handling of Hazardous Materials

Hazardous materials must be stored based on their compatibility, not in alphabetical order. Store materials of the same hazard together i.e. flammables with flammables, oxidizers with oxidizers etc. Refer to the section on Proper Storage and Handling of Chemicals in the main body of the CHP and Appendix J: Storing Chemicals Safely for additional guidelines.

Accidents, Spills and Emergencies

Hazardous chemical spills can be handled effectively when a plan of action has been developed. For accidents, emergencies, and spill awareness and/or procedures see Appendix D: Hazardous Materials Emergencies and Spills.

Disposal of Chemical Hazardous Materials

Federal, state and local laws strictly regulate the disposal of hazardous materials. The disposal of any hazardous material in the sewer, on the ground or in the regular trash is illegal. See the [EPA List of Hazardous Waste](#) section, [Texas CEQ Waste Index](#), and the [City of Beaumont Water and Sewer Services](#).

EHS & Risk Management is responsible for collecting hazardous waste and preparing it for shipment to an approved hazardous waste disposal facility.

Waste storage containers must be non-leaking, chemically compatible, safe, and clearly labeled with the words "Hazardous Waste." The label must also include the complete name(s) of the container's chemical constituents, the

hazards of the mixture, and the date when waste was first added to the container. Call EHS & Risk Management for pickups and include the following information: the name of the products to be picked up, the location, the person in charge of the area, a phone number, and the quantity to be picked up. If any of the chemicals are difficult to find SDSs for, please supply a copy.

Compressed gases, including non-returnable cylinders and aerosol cans, are not considered empty until they reach atmospheric pressure. EHS & Risk Management will dispose of these types of cylinders.

Other hazardous chemical containers with less than 110-gallon capacity are considered empty when as much material as possible has been removed through ordinary means (pouring, pumping, scraping, etc.), and there is less than 3% by weight of the original contents left in the container. Once these types of containers are empty, rinse out the container, let it air dry (preferably in a hood), and finally remove or deface the label prior to recycling or placing in the regular trash.

Disposal of Ink and Toner Cartridge

If an ink or toner cartridge has been used under normal circumstances until it is empty, it is not considered hazardous waste. Whenever possible, unused or defective cartridges should be returned to the supplier for replacement or credit. This practice minimizes the number of unused cartridges needing disposal. Any cartridges that cannot be returned and still contain residual ink or toner determined to be hazardous waste must be picked up by EHS & Risk Management for proper disposal. Contact EHS & Risk Management for assistance if unsure of how to dispose of any unused or defective ink or toner cartridges properly.

Biomedical Waste Disposal

Personnel who handle waste or sharps, or work in areas that handle human blood, tissues, and body fluids must comply with the policy and procedures for the handling and disposal of biomedical waste as required by [Texas Administrative Code Title 30, Part 1, Chapter 326 Medical Waste Management](#). This regulation requires, among other things, waste containment, marking and labeling, and disposal of potentially contaminated material. For assistance in disposal of sharps, and replacement of sharps disposal boxes, speak with your custodian.

Disposal of Radiological Waste

Only PIs may purchase and use radioactive material in a designated laboratory. Disposal of radioactive waste must be in compliance with Texas Department of State Health Services [Radiation Control Program](#) and the rules contained in the LU Radiation Safety Manual.



Laboratory Animal Waste Disposal Procedures

All research using animals at LU must be done in accordance with the guidelines set forth by the Institutional Animal Care and Use Committee. These requirements include the following:

Fixed Animal Tissues

Preserved specimens generated from teaching or research labs will be disposed of as biomedical waste. Disposal procedures will adhere to waste disposal guidelines with the LU Biological Safety Plan.

Research Animal Carcasses, Feces, and Bedding

These guidelines will vary depending upon how the animal tissue was used. Contact EHS & Risk Management for specific laboratory disposal requirements.

Mixed Waste

The creation of mixed waste (radioactive and chemical) is not allowed because of regulatory constraints and expense. Consult with EHS & Risk Management and the Radiation Safety Officer before generating mixed waste.

Waste Minimization

Departments should take the following steps to reduce the amount of generated chemical waste.

- Only purchase chemicals in quantities that can be used before the expiration of the material.
- Recycle surplus or unwanted chemicals.

Lamar University Hazardous Waste Disposal General Requirements

Do not dispose of hazardous waste through unapproved channels, including down the drain.

Do not dispose of unlike kinds of waste together.

Keep track of when you began collecting hazardous waste within a given container, as well as the composition/composition range to be expected with the material.

Contact EHS & Risk Management with any questions.

Special Waste

Special Waste refers to commonly used items that need special procedures for disposal. Examples of these include

aerosol cans, fluorescent light bulbs, ballasts, hazardous batteries, pharmaceuticals, and used oil.

Aerosol Cans

According to hazardous waste regulation, pressurized aerosol cans must be disposed of as hazardous waste. Aerosol cans also pose a potential risk of explosion if handled improperly. All departments that generate aerosol cans must follow these procedures:

- Collect and store all aerosol cans at Designated Accumulation Point(s) within the work area. Areas that generate large quantities of aerosol cans should have a 5-gallon trash container with a lid at the designated accumulation point.
- The container will be labeled as follows: Hazardous Waste Aerosol Cans Only.
- Request a pick-up from EHS & Risk Management when the container is full.

Fluorescent Light Bulbs

Fluorescent light bulbs contain enough elemental mercury to be categorized as a hazardous waste. Facilities Management is generally responsible for the collection and recycling of used fluorescent light bulbs.

Many retailers are now offering “green” fluorescent bulbs that claim not to be hazardous waste when disposed. These bulbs have different names but are often referred to as “green” bulbs because they have green markings, such as a green printed monogram, green end-caps, or other green indicators. Many varieties of “green” bulbs still contain low levels of mercury that, even at very low levels, can become air-borne and be deposited into the environment. For this reason, “green” fluorescent bulbs should be collected and disposed of as standard fluorescent light bulbs.

Ballasts

Ballasts control the starting and operating voltages and regulate the current passing through fluorescent lights. Some ballasts contain polychlorinated biphenyls (PCBs) that must be removed and disposed of as hazardous waste. Other non-PCB ballasts may contain DEHP (di (2-ethylhexyl) phthalate) which is classified by EPA as a hazardous substance. Ballasts must not be disposed in the trash. Facilities Maintenance is generally responsible for the collection and recycling of all ballasts.

Hazardous Batteries

Many batteries contain one or more hazardous chemical components, which are considered to be hazardous wastes. The following battery types are considered hazardous batteries and must be recycled by EHS & Risk



Management.

- Lead Acid
- Mercury
- Silver
- Lithium
- Nickel Cadmium (NiCad)
- Nickel Metal hydride (NiMH)

Common alkaline batteries (e.g. Duracell or Energizer batteries) are exempt and may be disposed of in the regular trash. Direct any questions concerning the type or nature of batteries used in the work area to EHS & Risk Management.

Pharmaceuticals

Pharmaceutical waste includes expired, recalled, damaged, overstocked, unwanted, or contaminated drugs, vaccines, supplements, vitamins, and sera. Effective February 22, 2019 pharmaceutical waste disposal is guided by 84 FR 5816, [Management Standards for Hazardous Waste Pharmaceuticals and Amendment to the P075 Listing for Nicotine](#).

Lamar University Student Health Clinic manages its own pharmaceutical waste.

PIs who are licensed to use controlled substances for teaching and research purposes are responsible for the proper disposition of their controlled pharmaceutical waste streams under the auspices of their license. EHS & Risk Management may be contacted as needed for assistance with the proper disposition of these substances.

EHS & Risk Management can also provide assistance on a case-by-case basis with the disposal of research and teaching-related prescription and over-the-counter medications.

All pharmaceutical waste should be kept in a secured location until removed for disposal. Under no circumstances should pharmaceutical waste be disposed in the regular trash or down the sink.

Used Oil

Used oil is regulated as waste in Texas. The rules governing disposal of used oil are located in [Texas Administrative Code Title 30, Chapter 324 \(Used Oil Recycling\)](#). Used oil is defined as any oil that has been refined from crude oil or synthetic oil, and, as a result of use, storage, or handling, has become contaminated



and unsuitable for its original purpose due to the presence of physical or chemical impurities or loss of original properties.

All used oil storage tanks and containers must be labeled with the words "Used Oil" in order to minimize the risk of cross contamination with other chemicals. All used oil containing tanks and containers must also have secondary containment (unless they are double-walled) that has the capacity to hold 110% of the volume of the largest tank or container within the containment area.

Since the risk posed to the environmental from a small, indoor spill is minimal, portable collection containers, satellite accumulation containers, and other small containers (those with a total capacity of equal to or less than 55 gallons) which are stored on an oil-impermeable surface inside a structure satisfy the requirements for secondary containment, as do portable collection containers on wheels that are emptied within 24 hours.

Used oil must not be discharged into soils, sewers, drainage systems, septic tanks, surface or ground waters, watercourses, or marine waters. Used compressor, pump, hydraulic or motor oils must be recycled. Collect used oil in proper containers (5-gal or less) which are labeled, "Used Oil" and contact EHS & Risk Management for pickup.

Note: Only material generated on campus will be managed by EHS & Risk Management. Do not bring personal material from home.



Appendix N: Lab Access Guidelines

Introduction

Laboratories potentially pose physical, chemical, biological, and/or radiation hazards to individuals who gain access to them.

It is the objective of Lamar University (LU) to promote safety for all individuals in our laboratories. As such, these laboratory access guidelines shall be strictly enforced by the Provost, Deans, Directors, their subordinates, and Lamar University Police Department (LUPD).

Repercussions for violation of this policy shall be issued by the Provost, Deans, and Directors.

It should be understood that every person who enters the laboratory at LU agrees not only to following these guidelines, but also to following all applicable federal, state, municipal, and university policies, procedures, and laws. In addition to LU sanctions and disciplinary actions, failure to comply may result in criminal and/or civil penalties.

EHS & Risk Management shall serve as a resource for evaluation of compliance.

This policy describes laboratory access requirements for research laboratories.

Questions about the content in this document should be directed to the Director, EHS & Risk Management.

Research Laboratory Access Policy

This section affects access to all research laboratories and facilities. It applies directly to principal investigators (PI), laboratory / facility managers, post-doctoral research fellows (post-docs), laboratory technicians (lab techs), graduate students, undergraduate students, volunteers, and visiting researchers.

Any person who intends to engage in research activities in any of the university's research laboratory facilities shall participate in a LU mandated research laboratory safety briefing conducted by the laboratory PI. This safety briefing shall include, at a minimum, an overview of the Chemical Hygiene Plan (CHP), an explanation of any hazards present within the lab, and any necessary safety measures while working within the lab. This briefing shall be repeated annually and records sent to EHS & Risk Management, who will maintain archives.

PIs are considered the authority on the research and other laboratory activities in which they, their post-docs, staff, and students engage. They are also considered the responsible parties for themselves and all others who either work, study, investigate, or enter their laboratory facilities. It is ultimately their responsibility to ensure that faculty, students, staff, volunteers, and visitors have all appropriate safety training completed and the required training records, liability waivers, and other documents filed with EHS & Risk Management before entry into laboratory facilities shall be permitted. Enforcement of this policy for all subordinates is the responsibility of the PI.



Building closures due to emergencies, weather, or other unexpected events may prevent building and/or lab access. In these situations, specific access restrictions will be announced by university authorities and shall be observed.

After the appropriate safety training is completed and documented, laboratory access shall be granted with the provision that the stipulation from the appropriate sections below be followed.

Key Policy

The PI for each laboratory will list on the research protocol the students, staff, and faculty involved in the particular research. From these listed participants, the PI will decide who is authorized to possess laboratory door keys. The PI will complete the standard [LU Key Request Form](#). Both the PI and Assistant Provost for Programming are required to sign the key request form before it is routed through normal permissions. The key request should not be authorized unless the requestor has completed all required training and registration.

When the research documented in an approved protocol ends, the PI is responsible for collecting the issued laboratory keys and returning them to Facilities Management. If a participant leaves the research team, the PI is responsible for collecting any issued keys and returning them to Facilities Management.

After-Hours Laboratory Entrance

Persons entering or present in a LU Building after posted business hours must notify Lamar University Police Department (LUPD) of their presence and location inside the building. If working alone after hours, note that working alone in a laboratory is prohibited when working with an immediately hazardous material, equipment, or in an area that, if safety procedures fail, could reasonably result in injury (see Working Alone Policy).

Persons entering a laboratory after posted business hours will possess a form authorizing entry to the laboratory and signed by the PI. A copy of the form will also be on file at LUPD dispatch. Persons occupying a university laboratory after posted business hours will present the appropriate form upon request of a LUPD officers or security personnel.

Persons must also notify LUPD upon leaving a laboratory after posted business hours.